



**ASE® 200 ACCELERATED SOLVENT EXTRACTOR
OPERATOR'S MANUAL**

Now sold under the
Thermo Scientific brand

Thermo
SCIENTIFIC

© 1999 Dionex Corporation

Document No. 031149
Revision 04
December 1999

©1999 by Dionex Corporation
All rights reserved worldwide.
Printed in the United States of America.

This publication is protected by federal copyright law. No part of this publication may be copied or distributed, transmitted, transcribed, stored in a retrieval system, or transmitted into any human or computer language, in any form or by any means, electronic, mechanical, magnetic, manual, or otherwise, or disclosed to third parties without the express written permission of Dionex Corporation, 1228 Titan Way, Sunnyvale, California 94088-3603 U.S.A.

DISCLAIMER OF WARRANTY AND LIMITED WARRANTY

THIS PUBLICATION IS PROVIDED "AS IS" WITHOUT WARRANTY OF ANY KIND. DIONEX CORPORATION DOES NOT WARRANT, GUARANTEE, OR MAKE ANY EXPRESS OR IMPLIED REPRESENTATIONS REGARDING THE USE, OR THE RESULTS OF THE USE, OF THIS PUBLICATION IN TERMS OF CORRECTNESS, ACCURACY, RELIABILITY, CURRENTNESS, OR OTHERWISE. FURTHER, DIONEX CORPORATION RESERVES THE RIGHT TO REVISE THIS PUBLICATION AND TO MAKE CHANGES FROM TIME TO TIME IN THE CONTENT HEREINOF WITHOUT OBLIGATION OF DIONEX CORPORATION TO NOTIFY ANY PERSON OR ORGANIZATION OF SUCH REVISION OR CHANGES.

TRADEMARKS

AutoASE™, AutoSeal™, and DX-LAN™ are trademarks of Dionex Corporation.
ASE® 200 is a registered trademark of Dionex Corporation.
N-EVAP™ is a trademark of Organomation Associates, Inc.
Teflon®, Tefzel®, and Viton® are registered trademarks of E.I. duPont de Nemours & Co.
TurboVap® is a registered trademark of Zymark Corporation.

PRINTING HISTORY

Revision 01, June 1995
Revision 02, February 1996
Revision 03, March 1997
Revision 04, December 1999

Contents

1 • Introduction

1.1	ASE 200 Options	1-2
1.2	About This Manual	1-3
1.2.1	Typefaces	1-3
1.2.2	Safety Messages and Notes	1-4
1.2.3	Symbols	1-5

2 • Description

2.1	Operating Features	2-1
2.1.1	Control Panel Display	2-3
2.1.2	Control Panel Keypad	2-5
2.1.3	Sample Cells, Rinse Tubes, and Cell Tray	2-7
2.1.4	Collection Vials, Rinse Vials, and Vial Tray	2-8
2.1.5	Solvent Reservoir Compartment	2-9
2.1.6	Electronics Area	2-10
2.2	Extraction Process	2-11
2.3	Operating Modes	2-22
2.3.1	Local Mode	2-22
2.3.2	Remote Mode	2-22
2.4	Method and Schedule Control	2-23

3 • Operation and Maintenance

3.1	Preparing to Run	3-1
3.1.1	Solvent Selection and Preparation . . .	3-1
3.1.2	Filling the Solvent Reservoir	3-2
3.1.3	Sample Preparation	3-4
3.1.4	Cell Selection and Filling	3-6
3.1.5	Vial Selection and Loading	3-11
3.1.6	Rinsing/Priming the System	3-14
3.1.7	Automatic Rinsing Between Samples .	3-15
3.1.8	Operation with an External Device . . .	3-16
3.2	Methods and Schedules	3-24
3.2.1	Creating Methods	3-25
3.2.2	Example Methods	3-30
3.2.3	Creating Schedules	3-34
3.2.4	Example Schedules	3-36
3.3	Method Development Guidelines	3-40
3.4	Running Extractions	3-42
3.4.1	Running Under Method Control	3-42
3.4.2	Running Under Schedule Control	3-45
3.4.3	Aborting a Run	3-46
3.5	Post-Extraction Procedures	3-47
3.5.1	Cleaning the Cells	3-47
3.5.2	Processing Extracts	3-47
3.6	Printing Reports	3-48
3.7	Routine Maintenance	3-49
3.7.1	Daily Maintenance	3-49
3.7.2	Periodic Maintenance	3-49
3.8	Shutdown	3-51

4 • Troubleshooting

4.1	Error Messages	4-1
4.2	System Stopped	4-20
4.3	Liquid Leaks	4-22
4.4	Gas/Air Leaks	4-24
4.5	Reports Do Not Print	4-25

5 • Service

5.1	Replacing the Cell PEEK Seal and Teflon O-Ring	5-2
5.2	Replacing Tubing and Fittings	5-3
5.3	Cleaning and/or Replacing Pump Check Valves	5-4
5.4	Replacing Piston Seals	5-7
5.5	Replacing the Pressure Relief Valve	5-10
5.6	Replacing the Static Valve	5-11
5.7	Replacing Needles	5-12
5.7.1	Vent Needle	5-12
5.7.2	Source Needle	5-14
5.8	Changing the Main Power Fuses	5-15
5.9	Calibrating the Hydrocarbon Sensor	5-16
5.10	Replacing the Hydrocarbon Sensor	5-18

A • Specifications

A.1	Electrical	A-1
A.2	Environmental	A-1
A.3	Physical	A-1
A.4	Pneumatic	A-1

Contents

A.5	Display and Keypad	A-2
A.6	Extraction Cells and Tray	A-2
A.7	Collection Vials and Trays	A-2
A.8	Interior Components	A-2

B • Installation

B.1	Facility Requirements	B-1
B.2	Installation Instructions	B-2
B.2.1	Air/Nitrogen Connections	B-2
B.2.2	Electrical Connections	B-5
B.2.3	DX-LAN Network Connections (Optional)	B-7
B.2.4	Check Pressure Readings	B-9
B.2.5	Solvent Reservoir Compartment Connections	B-11
B.2.6	Vial Tray Installation	B-15
B.2.7	Cell and Rinse Tube Inspection	B-15
B.2.8	Power-Up	B-17
B.2.9	Rinsing/Priming the System	B-18
B.3	Module Setup	B-19
B.4	Printer Connections (Optional)	B-22

C • Diagnostic Screens

C.1	Power-Up Screen	C-1
C.2	Regulators Screen	C-2
C.3	Error Log Screen	C-4
C.4	Hydrocarbon Calibration Screen	C-5

D • Reordering Information

E • TTL and Relay Control

E.1	TTL and Relay Output Operation	E-1
E.2	TTL Input Operation	E-1
E.2.1	TTL Input Signal Modes	E-2

Index

Contents

1 • Introduction

The ASE® 200 Accelerated Solvent Extractor is an automated system for extracting organic compounds from a variety of solid and semisolid samples. The ASE 200 accelerates the traditional extraction process by using solvent at elevated temperatures. Pressure is applied to the sample extraction cell to maintain the heated solvent in a liquid state during the extraction. After heating, the extract is flushed from the sample cell into a standard collection vial and is ready for analysis.

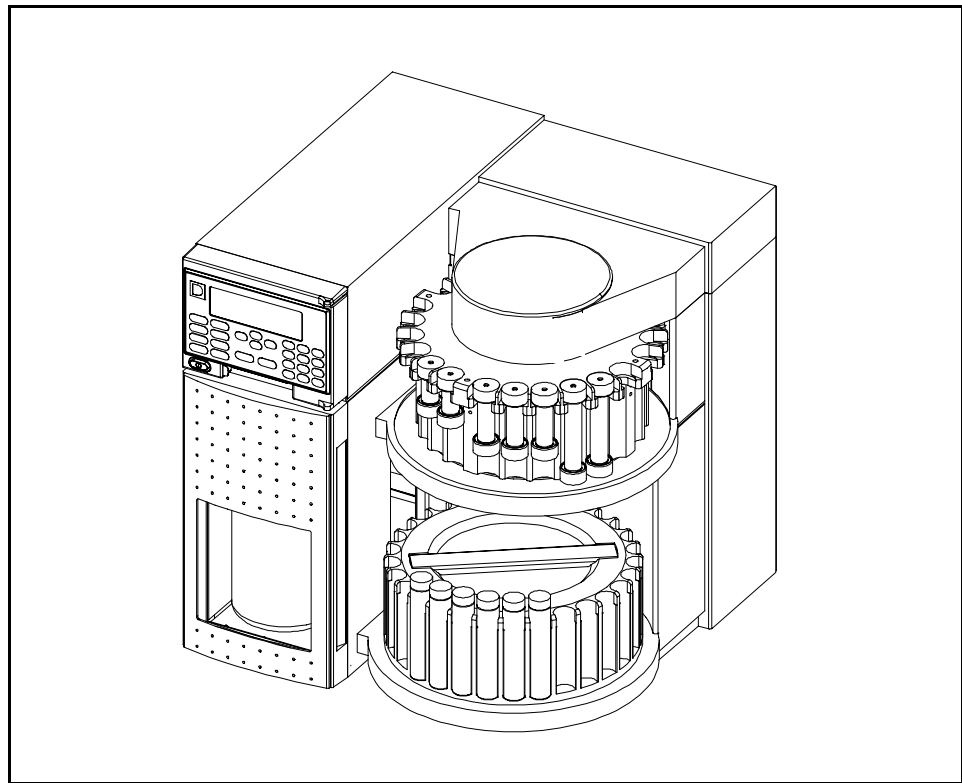

Figure 1-1. ASE 200 Accelerated Solvent Extractor

1.1 ASE 200 Options

Two optional products are available for the ASE 200: the ASE 200 Solvent Controller and AutoASE™ software.

When operated in conjunction with an ASE 200 Solvent Controller, the ASE 200 can do the following:

- Change solvents between extractions so that the same sample is extracted with a different solvent, or so that each remaining sample on the carousel is extracted with a solvent other than the one used for the previous sample.
- Select from up to four different solvent reservoirs for extractions.
- Mix two, three, or four different solvents.

ASE 200 Solvent Controller operation can be controlled from either the ASE 200 front panel or from AutoASE software. The *ASE 200 Solvent Controller Installation Instructions* (Document No. 031277) contains more information.

AutoASE software provides computer control of up to eight ASE 200 modules and ASE 200 Solvent Controllers. All parameters that can be selected from the ASE 200 front panel are available from AutoASE, as well as some additional ones.

Communication between the ASE 200 and AutoASE requires the installation of both a DX-LAN™ interface card (P/N 044195) and a DX-LAN cable (P/N 960404). The *AutoASE Software User's Guide* (Document No. 031259) provides complete software installation and operating instructions.

To order either of these options, contact the nearest Dionex office.

1.2 About This Manual

Chapter 1, **Introduction**, introduces the ASE 200 and explains the conventions used in this manual (including safety-related messages).

Chapter 2, **Description**, describes the physical aspects of the ASE 200 and the extraction process.

Chapter 3, **Operation and Maintenance**, discusses operating procedures and presents several examples of how to create and run methods and schedules. Routine preventive maintenance requirements are included.

Chapter 4, **Troubleshooting**, lists minor operating problems and provides step-by-step procedures to isolate and eliminate their sources.

Chapter 5, **Service**, presents step-by-step instructions for routine service and parts replacement procedures.

Appendix A, **Specifications**, contains the ASE 200 specifications and installation site requirements.

Appendix B, **Installation**, describes how to install the ASE 200.

Appendix C, **Diagnostic Screens**, describes the ASE 200 diagnostic screens.

Appendix D, **Reordering Information**, lists spare parts.

Appendix E, **TTL and Relay Control**, describes relay and TTL input and output functions.

1.2.1 Typefaces

- Capitalized bold type indicates a front panel button:
Press **Start** to begin running the method.
- Uppercase bold type indicates the name of a menu, a screen, or an on-screen field:
Display the **METHOD EDITOR** screen.
Move the cursor to the **EDIT#** field.

1.2.2 Safety Messages and Notes

The ASE 200 meets European, EMC, and safety requirements per Council Directives 73/23/EEC and 89/336/EEC, EN 61010-1:1993 (safety), EN 50082-1:1992 (susceptibility), and EN 55011:1991 (emissions). The CE and GS safety label on the ASE 200 attests to compliance with these standards.

To ensure operator safety, do not use the ASE 200 for any applications other than those described in this manual. If there is a question regarding appropriate usage, contact Dionex before proceeding.

This manual contains warnings and precautionary statements that, when properly followed, can prevent personal injury to the user and/or damage to the ASE 200. Safety messages appear in bold type and are accompanied by icons.



Indicates an imminently hazardous situation which, if not avoided, will result in death or serious injury.



Indicates a potentially hazardous situation which, if not avoided, may result in death or serious injury.



Indicates a potentially hazardous situation which, if not avoided, may result in minor or moderate injury.



Indicates that the function or process of the instrument may be impaired. Operation does not constitute a hazard.

Informational messages also appear throughout this manual. These are labeled NOTE and are in bold type:

NOTE

NOTES call attention to certain information. They alert the user to an unexpected result of an action, suggest how to optimize instrument performance, etc.

1.2.3 Symbols

The symbols below appear on the ASE 200 or on ASE 200 labels.



Alternating current



Protective conductor terminal



Power supply is on



Power supply is off

ASE 200 Operator's Manual

2 • Description

- Section 2.1 describes the operating features and components of the ASE 200.
- Section 2.2 describes the extraction process.
- Section 2.3 describes the two operating modes for the ASE 200.
- Section 2.4 describes both method and schedule control of the ASE 200.

2.1 Operating Features

Figure 2-1 illustrates the main operating features of the ASE 200.

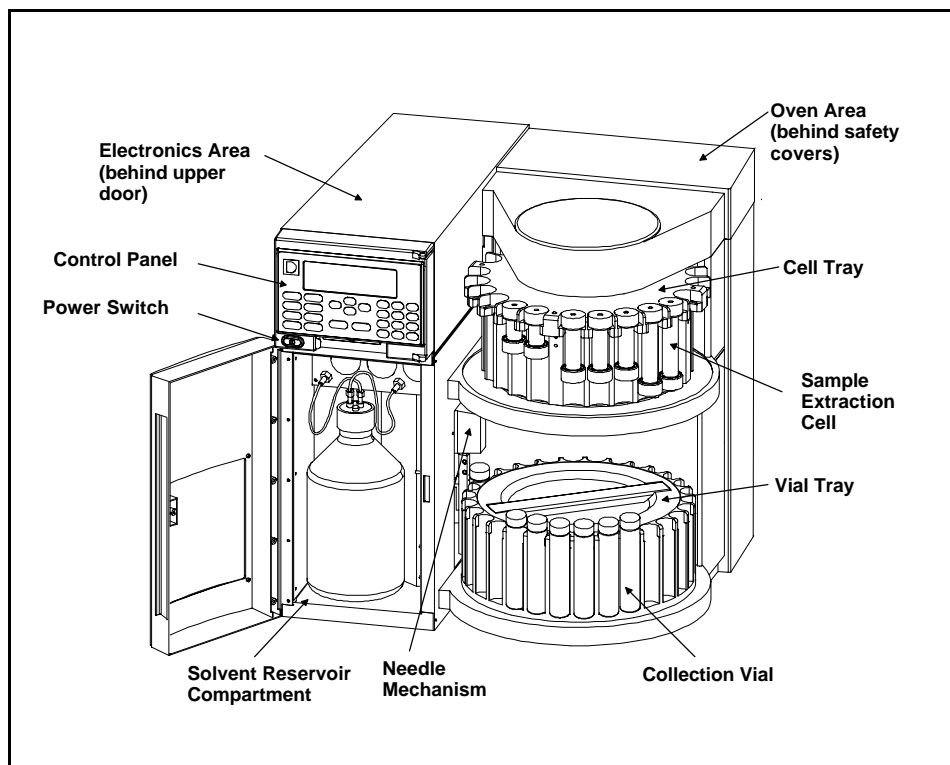

Figure 2-1. ASE 200 Operating Features

Power Switch

The power switch actuator is at the lower left corner of the upper door. The door must be fully closed for the actuator to operate. When the upper door is open, press the main power switch, located behind the door, to turn the ASE 200 on and off.

Control Panel

The control panel on the upper door of the ASE 200 contains the liquid crystal display (LCD) and the membrane keypad (see Figure 2-2). The upper door provides access to the ASE 200 electronics.

Solvent Reservoir Compartment

The lower door provides access to the solvent reservoir, the waste vial, and the pressure gauges.

Cell Tray and Extraction Cells

The cell tray, on the upper right of the ASE 200, holds the sample extraction cells. The prepared sample is loaded into these cells.

Vial Tray and Collection Vials

The vial tray, on the lower right, holds the collection vials. After extraction, these vials contain solvent and the analytes extracted from the sample.

Oven Area

The oven is housed at the rear of the ASE 200. This area also houses the AutoSeal™ arms, which move the cell into and out of the oven, and which seal the cell during the extraction.

Needle Mechanism

The needle mechanism, at the left of the vial tray, pierces the collection vial septum, allowing the extract to flow from the cell into the vial.

2.1.1 Control Panel Display

The LCD, also called the screen, displays status and operating information. Fields on the screen that are in reverse video (blue letters on white background) can be edited. Normal video fields display information only.

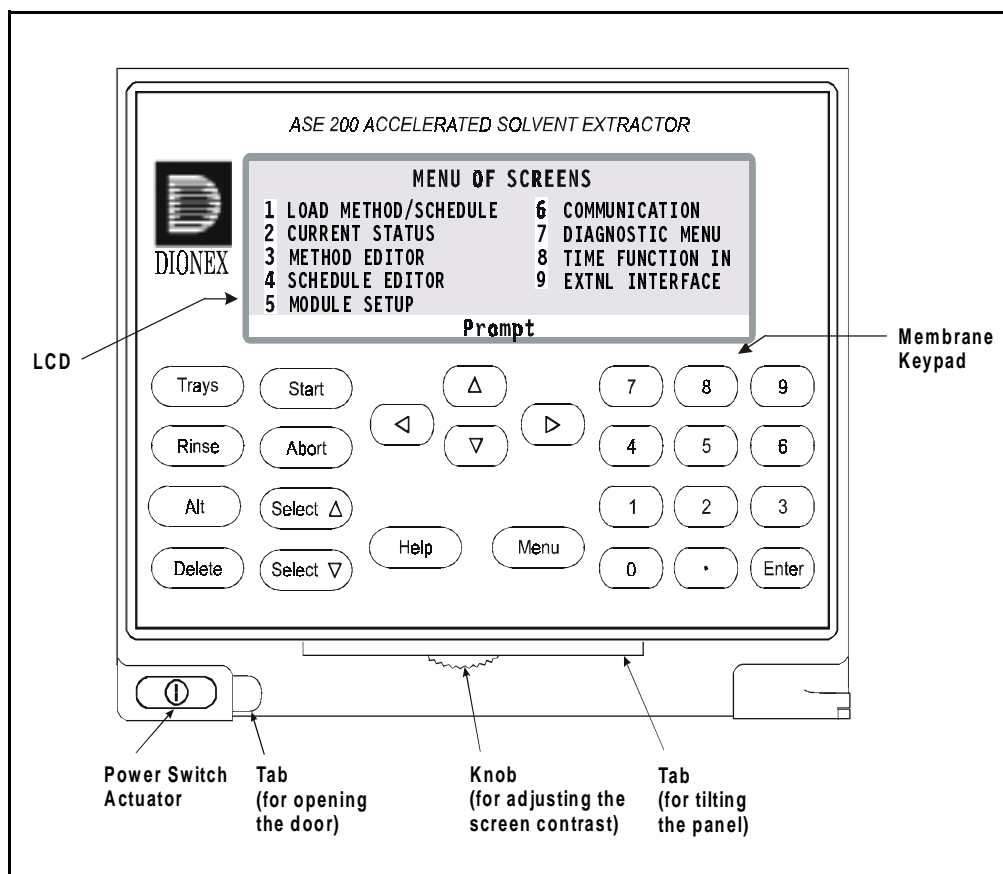

Figure 2-2. ASE 200 Control Panel

Three adjustments are available for improving screen visibility:

- The screen contrast can be adjusted with the knurled knob in the recess below the keypad (see Figure 2-2).
- The brightness of the screen's backlight can be adjusted by resetting this option on the **MODULE SETUP** screen (see Section B.3).
- The control panel can be tilted to four positions. To tilt the panel, support the upper door of the enclosure at the left side (to prevent it from opening) and lift firmly on the tab in the middle of the recess below the keypad (see Figure 2-2). Push on the tab to return the panel to its vertical position.

At power-up, the copyright and microprocessor code revision levels are displayed for a few seconds before the **MENU OF SCREENS** appears. From the menu, select either an individual operational screen or the **DIAGNOSTIC MENU** screen.

There are two ways to select a screen from the menu:

- Press the number button that corresponds to the screen's number on the menu (1–9).
- Move the cursor to the screen name and press **Enter**.

2.1.2 Control Panel Keypad

Unless the ASE 200 is under computer control, pressing a keypad button either directly affects ASE 200 operation or affects a screen function. Table 2-1 summarizes the button functions.







Button	Function
The following buttons affect ASE 200 operation directly:	
	Pressing the Trays button toggles the cell and vial trays between the engaged and free spin modes. LEDs on the button indicate the current mode. When the left LED is lighted, the vial and cell trays can be rotated manually. Switch to free spin during loading and unloading of vials and cells, and when removing the vial tray from its support spindle.
	When the right LED is lighted, the tray drive mechanisms are engaged and cannot be moved manually. Toggling from free spin to engaged causes the trays to rotate to the home position (i.e., vial 1 and cell 1 are ready for the next run). Starting a run automatically engages the trays. The Trays button is disabled during a run.
	Starts a manual rinse cycle, which is used to prime the pump and to rinse after a solvent change. The trays rotate to the nearest rinse vial and rinse tube. Approximately 4 mL of solvent is then pumped through the system and into the rinse vial. This button functions only when ASE is idle.
	Starts the currently loaded method or schedule. When the system is idle, the LED on the left side of the button is lighted. When a run is in progress, the LED on the right is lighted. This button is disabled when the ASE 200 is in Remote mode.
	
	Interrupts the current run. The pump turns off, valves close, and all flow stops. The screen displays a list of options for selection. See Section 3.4.3 for more information.

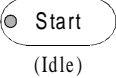
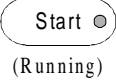

Table 2-1. Front Panel Button Functions

Button	Function
--------	----------

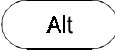
The following buttons control functions:

	From the SCHEDULE EDITOR screen, press Alt followed by Select Δ to delete the current line and move up the lines below the deleted line. Press Alt followed by Select ∇ to insert a new line. This button is disabled when the ASE 200 is in Remote mode.
---	--

	Removes the value from the current entry field. This button is disabled when the ASE 200 is in Remote mode.
---	---

	The Select buttons cycle between predetermined options in entry fields. To confirm the selected value, press Enter or move the cursor out of the field by pressing an arrow button. In fields that have predetermined numeric choices, Select Δ increases the value by one unit and Select ∇ decreases the value by one unit. Holding down a Select button increases (or decreases) the value continuously.
	

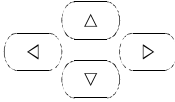
	The arrow buttons move the cursor in the direction of the arrow to the next entry field if one exists. At the end of a line, the left arrow wraps the cursor around to the next entry field on the line above; the right arrow wraps the cursor to the next entry field on the line below. The up and down arrows do not wrap around.
---	---

After entering a new value in an entry field, pressing an arrow button to move to another field saves the change.

	Displays a context-sensitive help screen.
---	---

	Displays a list of the available screens.
---	---

	The numeric buttons enter the selected number into the current entry field. From a menu, pressing a numeric button opens the corresponding screen.
---	--

	Saves changes made in entry fields. When a menu screen is displayed, pressing Enter opens the highlighted screen.
---	--

Table 2-1. Front Panel Button Functions (continued)

NOTE

Appendix D contains part numbers for cells, vials, and other consumable accessories.

2.1.3 Sample Cells, Rinse Tubes, and Cell Tray

The cell tray holds 24 sample cells and four rinse tubes. Sample cells are available in the following sizes: 1 mL, 5 mL, 11 mL, 22 mL, and 33 mL. Interchangeable caps screw onto each end of the cell body and are hand-tightened. Inside each cap is a stainless steel frit and a PEEK seal. During a run, the cell caps are compressed to form a tight seal between the caps and the cell body.

IMPORTANT

The sealing surfaces of the 1 mL and 5 mL cells are larger than those of the standard cells (11 mL, 22 mL, and 33 mL). Before installing an end cap previously used on a standard cell onto either a 1 mL or 5 mL cell body, first install a new PEEK seal in the cap (see Section 5.1).

Each cell cap contains an external O-ring. A Teflon® O-ring (P/N 049457, pkg. of 50) is standard. Use a Viton® O-ring (P/N 056325, pkg. of 50) for high temperature applications, such as dioxins.

Install the sample cells in any order. During a run, sensors determine the cell size in each tray position.



To avoid personal injury, exercise caution when the tray is in motion.

Rinse tubes are small-diameter metal tubes that fit into the four rinse positions in the cell tray (see Figure 2-3). During a rinse cycle, the tray rotates to the nearest rinse position that ensures that the heated cells remain behind the safety cover over the oven (see Figure 2-1). Solvent passes directly through the rinse tube during the cycle.

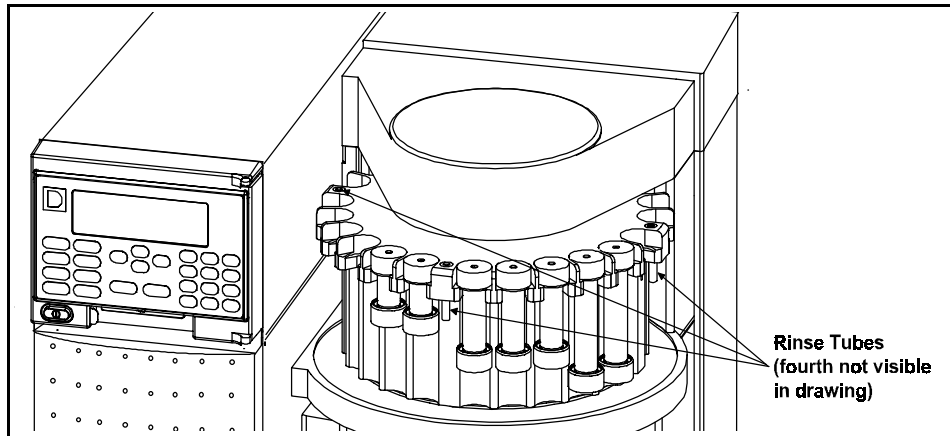

Figure 2-3. Rinse Tubes

2.1.4 Collection Vials, Rinse Vials, and Vial Tray

The vial tray holds 26 collection vials and four rinse vials. Collection vials are standard EPA-type VOA (volatile organic analysis) glass vials. The following table lists the vial types available from Dionex.

Collection Vial	Part Number
40 mL, clear glass	048783 (pkg. of 72)
40 mL, amber glass	048780 (pkg. of 72)
40 mL graduated, clear glass	055442 (pkg. of 6)
60 mL, clear glass	048784 (pkg. of 72)
60 mL, amber glass	048781 (pkg. of 72)

The 40 mL graduated concentration vials can be used with the N-EVAP™ workstation, manufactured by Organomation Associates, Inc., or the Zymark TurboVap® workstation. The vials have grade A (5% tolerance) calibrated, stemmed tips.

The collection vial caps have solvent-resistant septa. During a run, the needle mechanism pierces the septum, creating a liquid flow path from the sample cell to the collection vial.

The four rinse vial positions (labeled R1, R2, R3, and R4) can accommodate 40 mL or 60 mL collection vials. During a rinse cycle, the tray rotates to a rinse position. Before starting

the rinse, if the vial sensors determine that the rinse vial is absent or full, the tray rotates to another rinse position. Solvent is then pumped through the system and collected in the rinse vial.



To avoid personal injury, exercise caution whenever the tray is in motion.

To adapt the vial tray positions for regular 40 mL vials, install removable inserts (P/N 049348) into the tray positions. To adapt the tray positions for graduated 40 mL vials, install vial spacers (P/N 055444) into the tray positions.

No inserts or spacers are required for the 60 mL vials.

2.1.5 Solvent Reservoir Compartment

The compartment behind the front lower door (see Figure 2-1) contains the solvent reservoir, waste vial, and pressure gauges.

The ASE 200 Ship Kit includes a 2-liter glass reservoir with shatterproof plastic coating (P/N 045901) and a bottle cap assembly (P/N 049496) with tubing and fittings for connecting the reservoir to the ASE 200.

NOTE

When an ASE 200 Solvent Controller is in use, install the solvent reservoirs in the Solvent Controller, not the ASE 200 reservoir compartment.

A 40 mL or 60 mL collection vial can be used to collect waste. The waste vial sits in a holder on the right side of the reservoir compartment. Two vent lines, one from the pressure relief valve and one from the needle mechanism, are connected to the top of the waste vial holder. The waste vial collects the small amounts of solvent vented through the two lines.

A vent outlet line is also connected to the waste vial holder. Gas is vented out this line to the rear panel, which can be connected to a hood. The ASE 200 Ship Kit includes additional vent tubing for this purpose.

Check the waste vial daily and empty whenever necessary.

2.1.6 Electronics Area

The ASE 200 electronics area is located behind the upper front door (see Figure 2-1). To open the door, pull on the tab located to the right of the main power actuator (see Figure 2-2).

A strip of eight 2-pin connectors (two relay outputs, two TTL outputs, and two TTL inputs) on the CPU card (see Figure B-15) allows the ASE 200 to communicate with an external sample preparation device. See Section 3.1.8 for details about implementing this feature.



Do not remove any of the electronics cards. There are no user-serviceable components on the cards. If servicing is required, it must be performed by qualified personnel and appropriate electrostatic discharge (ESD) handling procedures must be followed.

2.2 Extraction Process

Before starting an extraction, perform the following steps. Refer to Chapter 3 for instructions.

- Prepare samples and load them into the extraction cells.
- Place cells in the cell tray.
- Place collection vials in the vial tray.
- Create a method.
- Load the method.

The remainder of this section describes the automatic portion of the extraction process—the steps that the ASE 200 performs after you press **Start** to begin a run.

The extraction process consists of eight main steps:

- Loading the cell into the oven
- Filling the cell with solvent
- Heating the cell (equilibration)
- Static extraction
- Flushing with fresh solvent
- Purging solvent from the system
- End relief
- Unloading the cell

Figure 2-4 shows the solvent and gas flow path through key components of the ASE 200.

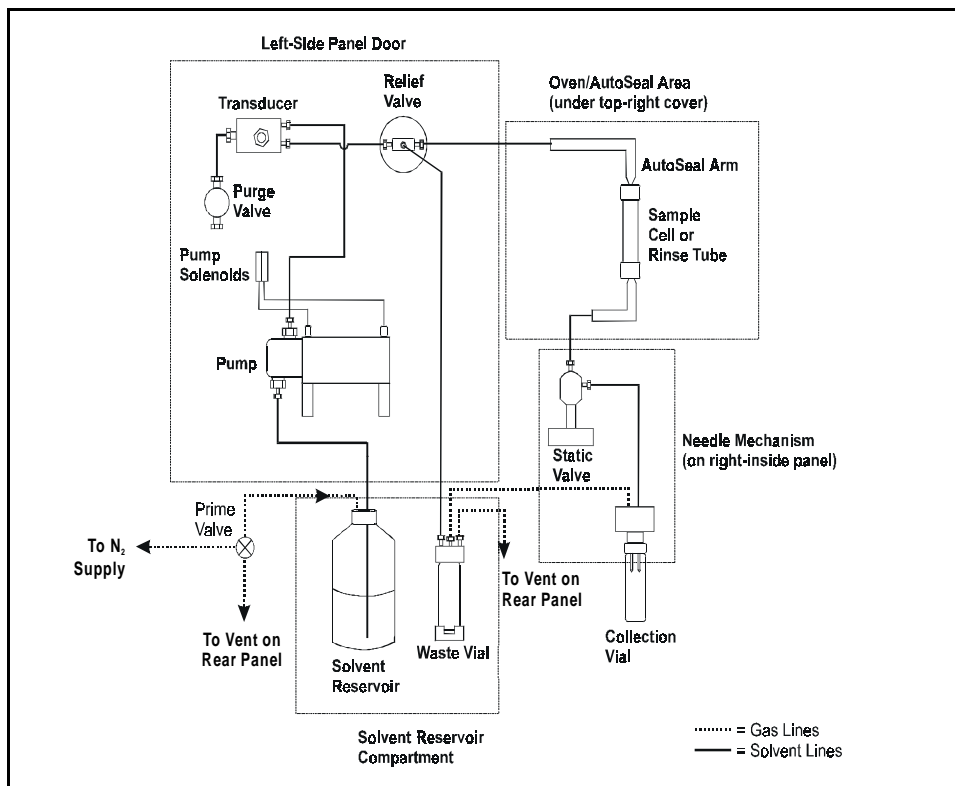

Figure 2-4. ASE 200 Schematic

During the extraction process, the **CURRENT STATUS** screen displays the step being run, as well as other operating parameters. Figure 2-5 is an example of the **CURRENT STATUS** screen. Table 2-2 describes the screen parameters.

SYSTEM STATUS: FILLING CELL			LOCAL
CONTROL:	METHOD	SCHEDULE:	
STEP TIME:		METHOD:	1
TEMPERATURE:	100 100 °C	CELL:	1
PRESSURE:	1500 500 psi	CELL SIZE:	22
STATIC O PUMP	0	VIAL:	1
PURGE C RELIEF C		VOLUME (mL):	8

Figure 2-5. Current Status Screen

Parameter	Description
SYSTEM STATUS	Current step (load, fill, heat, static, flush, purge, unload)
CONTROL	Current control type (method or schedule)
STEP TIME	Step's programmed time is first, followed by the elapsed time
TEMPERATURE	Programmed temperature is first, followed by the current temperature
PRESSURE	Programmed pressure is first, followed by the current pressure
STATIC PUMP PURGE RELIEF	Status of valves (C=closed, O=open)
SCHEDULE	Current schedule (if any)
METHOD	Current method
CELL	Current cell
CELL SIZE	Size of the cell (1 mL, 5 mL, 11 mL, 22 mL, or 33 mL). Note: This field displays "11" when a 1 mL or 5 mL cell is present because the length of these cells is equivalent to the length of the 11 mL cell.
VIAL	Current vial
VOLUME (mL)	Approximate amount of solvent delivered by the pump

Table 2-2. Current Status Screen Parameters

If no keypad buttons are pressed for a specified duration, an alternate status screen replaces the **CURRENT STATUS** screen (see Figure 2-6). Press any button to return to the **CURRENT STATUS** screen. To change the time delay for displaying the alternate status screen or to disable the screen, see Section B.3.

STATUS: STATIC	
STEP TIME: 5	4.5 MIN
SCHEDULE:	CELL: 1
METHOD: 1	VIAL: 1

Figure 2-6. Alternate Status Screen

The following sections describe each step in the extraction process.

Step 1: Loading the Cell

- The cell and vial trays rotate to the initial positions specified in the method or schedule. The needle mechanism pierces the vial.
- The AutoSeal arms pick up the cell and move it into the oven.
- The oven applies pressure to seal the cell.

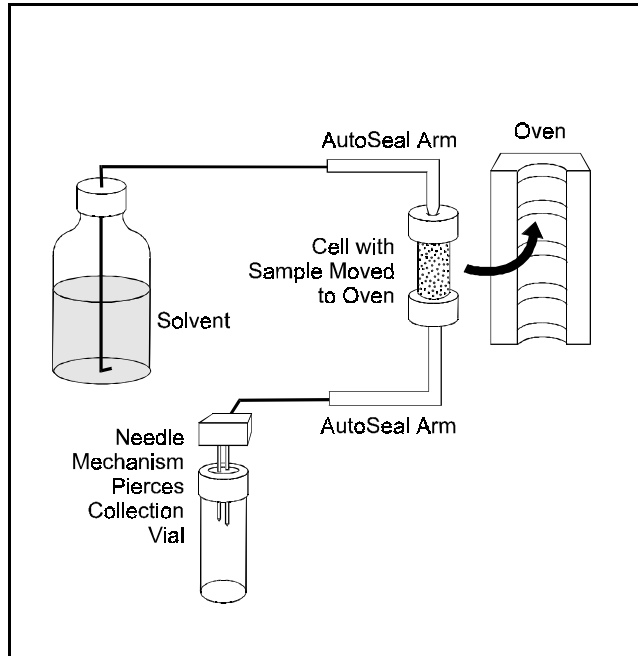

Figure 2-7. Extraction Process: Loading

SYSTEM STATUS: LOADING CELL			LOCAL
CONTROL:	METHOD		SCHEDULE:
STEP TIME:			METHOD: 1
TEMPERATURE:	100	100 °C	CELL: 1
PRESSURE:	1500	0 psi	CELL SIZE: 22
STATIC C PUMP	C		VIAL: 1
PURGE C RELIEF	C		VOLUME (mL):

Figure 2-8. Status Screen: Load Cell

NOTE

The oven begins heating to the programmed set point immediately after a method is loaded (before you press **Start** to begin the run). Cell loading begins when the oven is within 5 °C of the set point.

Step 2: Filling the Cell

- The pump begins pumping solvent into the cell.
- When the cell is full and the collection vial contains about 1 mL of solvent, the static valve closes and flow stops.

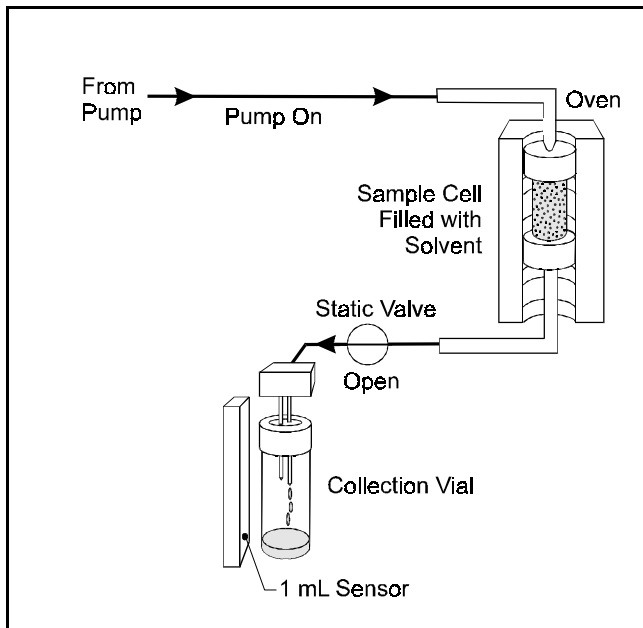

Figure 2-9. Extraction Process: Filling

SYSTEM STATUS:	FILLING CELL	LOCAL
CONTROL:	METHOD	SCHEDULE:
STEP TIME:		METHOD:
TEMPERATURE:	100 100 °C	CELL:
PRESSURE:	1500 500 psi	CELL SIZE:
STATIC O PUMP	0	VIAL:
PURGE C RELIEF C		VOLUME (mL):
		8

Figure 2-10. Status Screen: Filling the Cell

NOTE

If the sample cell does not fill within a 100-second time-out, the ASE 200 stops running, and advances to the next cell and vial. If the second cell does not fill within the time-out, the ASE 200 advances to the next cell and vial. If the third cell fails to fill within the time-out, all runs stop and an error message is displayed. The problem is usually caused by a block in the solvent flow path (see Chapter 4 for troubleshooting information).

**Steps 3 and 4:
Heating and Static**

- The cell is heated for a fixed time (optional) to ensure that the sample reaches thermal equilibrium.
- The static period occurs. Select the time (usually 5 minutes) in the method.
- During the heating and static steps, the static valve opens periodically to maintain the set point pressure in the cell.

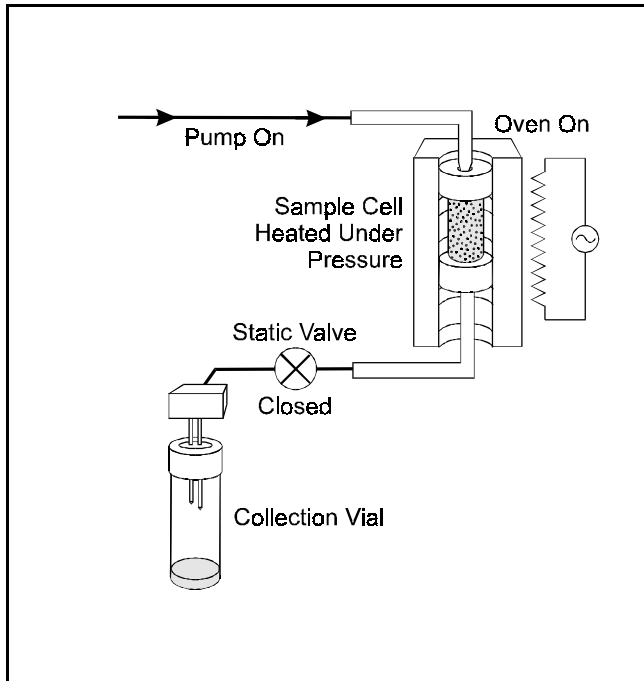

Figure 2-11. Extraction Process: Heating/Static

SYSTEM STATUS:	HEATING	LOCAL
CONTROL:	METHOD	SCHEDULE:
STEP TIME:	5 2.5 min	METHOD:
TEMPERATURE:	100 100 °C	CELL:
PRESSURE:	1500 1500 psi	CELL SIZE:
STATIC C PUMP	0	VIAL:
PURGE C RELIEF C		VOLUME (mL):
		13

Figure 2-12. Status Screen: Heating

NOTE

When the cell pressure exceeds the set point by 1.4 MPa (200 psi), the static valve opens to relieve pressure. Any solvent that exits the cell then is directed into the collection vial.

Step 5: Flushing

- The static valve opens and the extract flows into the collection vial.
- Fresh solvent is pumped through the cell (usually 50 to 100% of the cell volume).

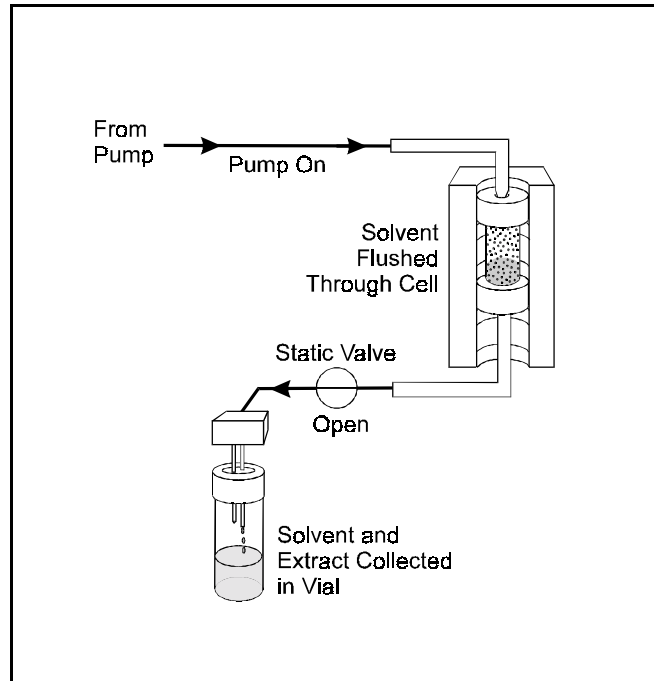

Figure 2-13. Extraction Process: Flushing

SYSTEM STATUS: FLUSHING			LOCAL
CONTROL:	METHOD		SCHEDULE:
STEP TIME:			METHOD: 1
TEMPERATURE:	100	100 °C	CELL: 1
PRESSURE:	1500	235 psi	CELL SIZE: 22
STATIC O PUMP	0		VIAL: 1
PURGE C RELIEF C			VOLUME (mL): 19

Figure 2-14. Status Screen: Flushing

Step 6: Purging

- The remaining solvent is displaced with purge gas.
- The collection vial now contains all of the solvent and the analytes extracted from the sample.

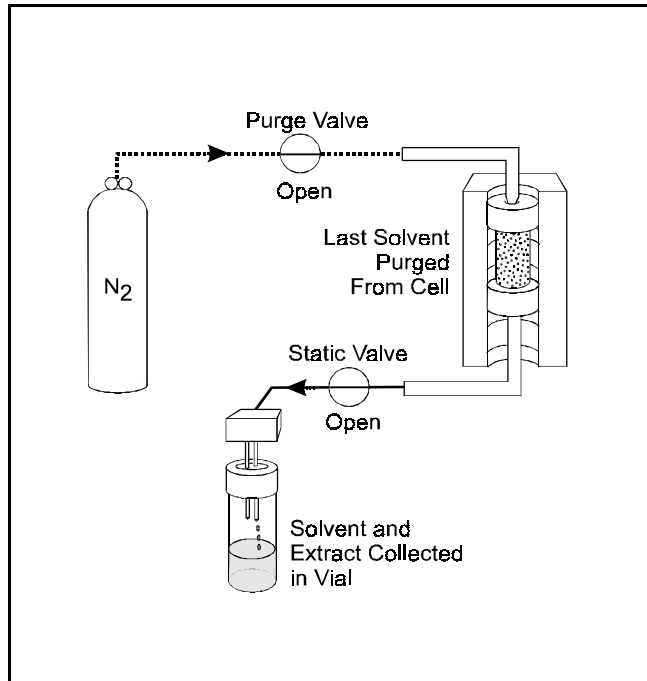

Figure 2-15. Extraction Process: Purging

SYSTEM STATUS: PURGING			LOCAL
CONTROL:	METHOD		SCHEDULE:
STEP TIME:	32 60 min		METHOD: 1
TEMPERATURE:	100 100 °C		CELL: 1
PRESSURE:	1500 152 psi		CELL SIZE: 22
STATIC O PUMP	C		VIAL: 1
PURGE O RELIEF	C		VOLUME (mL): 30

Figure 2-16. Status Screen: Purging

Step 7: End Relief

- Residual pressure is released from the extraction cell.

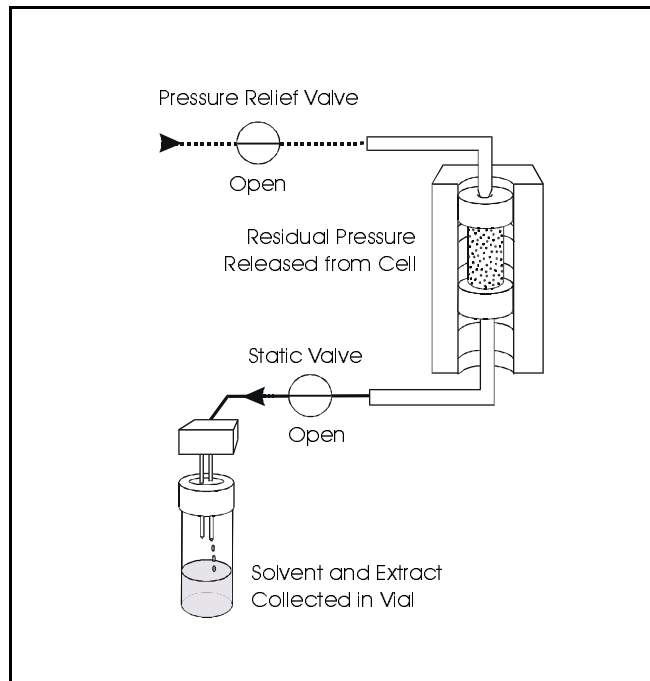

Figure 2-17. Extraction Process: End Relief

SYSTEM STATUS:	END RELIEF	LOCAL
CONTROL:	METHOD	SCHEDULE:
STEP TIME:	60 31 SEC	METHOD:
TEMPERATURE:	100 100 °C	CELL:
PRESSURE:	1500 0 psi	CELL SIZE:
STATIC O PUMP	C	VIAL:
PURGE C RELIEF	O	VOLUME (mL):
		30

Figure 2-18. Status Screen: End Relief

**Step 8:
Unloading the Cell**

- Pressure is vented from the system.
- The cell is unloaded from the oven and returned to the tray.
- The needle mechanism is removed from the vial.
- The trays advance to their next positions and the next run starts.
- The ASE 200 stops when all runs are completed.

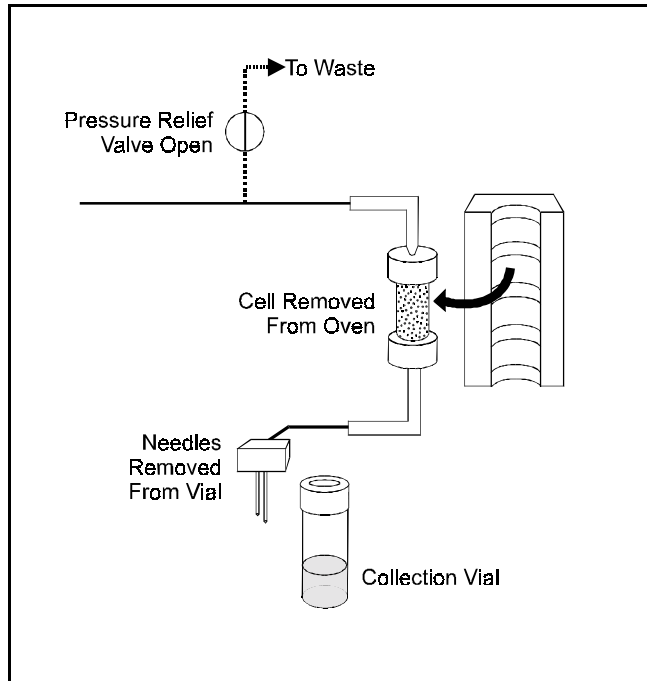

Figure 2-19. Extraction Process: Unloading the Cell

SYSTEM STATUS: UNLOADING CELL				LOCAL
CONTROL:	METHOD		SCHEDULE:	
STEP TIME:			METHOD: 1	
TEMPERATURE:	100	100 °C	CELL: 1	
PRESSURE:	0	1 psi	CELL SIZE: 22	
STATIC C PUMP	C		VIAL: 1	
PURGE C RELIEF	C		VOLUME (mL): 30	

Figure 2-20. Status Screen: Unloading



Cells are extremely hot after an extraction. Allow the cells to cool for at least 15 minutes before handling, especially if the cells were heated over 50 °C.

During an extraction, solenoids turn the pump flow on and off. In addition, the following valves control solvent flow and pressure in the system:

- The static valve controls the flow of solvent to the collection vial. Pressure in the cell increases when the pump is on and the static valve is closed.
- The purge valve controls gas pressure to the cell.
- The pressure relief valve releases any residual pressure after an extraction.
- The prime valve controls gas pressure to the solvent bottle.

Figure 2-21 illustrates the positions of the valves at each step of the extraction process.

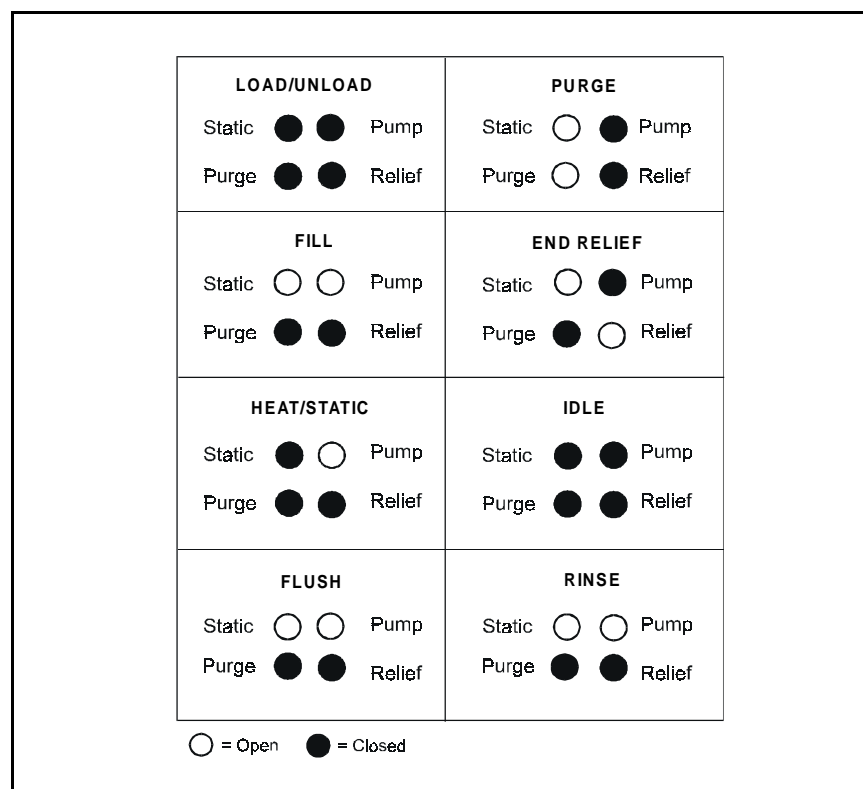

Figure 2-21. Valve Positions During Extraction Process

2.3 Operating Modes

The ASE 200 has two operating modes: Local and Remote. Select the mode from the **MODULE SETUP** screen (see Section B.3).

2.3.1 Local Mode

When the ASE 200 power is turned on, it defaults to Local mode. In Local mode, operation is controlled by commands input directly from the ASE 200 keypad.

2.3.2 Remote Mode

In Remote mode, the ASE 200 accepts operating commands from AutoASE software via the DX-LAN interface. When Remote mode is selected, the word **REMOTE** appears in the upper right corner of the **CURRENT STATUS** screen and the screen displays the method steps as they are executed.

In Remote mode, the following conditions apply:

- Only three ASE 200 keypad buttons are functional: **Trays**, **Rinse**, and **Abort**.
- The **LOAD METHOD OR SCHEDULE** screen is not accessible. Although other screens can be displayed, only one field can be edited: the operating mode can be toggled from Remote to Local on the **MODULE SETUP** screen.
- All global print or rinse commands selected from the keypad are disregarded.

Sending an operating command from AutoASE automatically switches the ASE 200 to Remote mode, if it is not already selected. However, AutoASE cannot reset the mode to **LOCAL**.

To return to **LOCAL** mode after running AutoASE, open the **MODULE SETUP** screen and reset the mode.

2.4 Method and Schedule Control

NOTE

This section describes how to create methods and schedules from the ASE 200 front panel. For instructions on creating methods and schedules from AutoASE software, refer to the AutoASE manual.

Before running an extraction, you must create a *method* that defines operating conditions for the run. A method specifies the following parameters:

- Cell heating time
- Oven temperature
- Cell pressure
- Amount of solvent to flush through the cell
- Solvent types and percentages (only when the ASE 200 Solvent Controller is installed)
- Purge time

The ASE 200 can store up to 24 methods. Section 3.2.1 describes how to create methods from the ASE 200 front panel.

For a series of extractions, you can define a *schedule* of runs. A schedule specifies the method to run on each sample in the schedule, the sample cell assigned to each collection vial, and the rinse status after each sample run. The ASE 200 can store up to 24 schedules. Section 3.2.3 describes how to create schedules from the ASE 200 front panel.

The ASE 200 provides two control modes:

- Method control runs the same method on each consecutive sample loaded in the tray.
- Schedule control runs a series of methods according to the schedule definition.

3 • Operation and Maintenance

3.1 Preparing to Run

3.1.1 Solvent Selection and Preparation

When developing a new extraction method, select a solvent or solvent mixture that has a high solubility for the analytes of interest, but not for the sample matrix. If you have been using another extraction method (Soxhlet, for example), continue using the same solvent with the ASE 200.



Do not use solvents with an autoignition point of 40 to 200 °C. The table below lists some solvents that should *not* be used with the ASE 200. If you have a question about solvent suitability, contact Dionex.

Solvents Not to Use		Autoignition Point
Carbon disulfide	CS ₂	100 °C
Diethylether	(C ₂ H ₅) ₂ O	180 °C
1,4-Dioxane	C ₄ H ₈ O ₂	180 °C

Follow these guidelines when selecting and preparing solvents:

- Use HPLC- or pesticide-grade solvents.
- Use organic or aqueous solvents.
- Use single- or multiple-component solvents.

- Weak acids and bases (for example, acetic acid and potassium hydroxide) or other noncorrosive additives may be used, but should be added in small percentages (<5% by volume) to the solvent system.

NOTE

After extracting with acidic solvents or basic solvents, rinse the system with 100% organic solvent or with distilled water before overnight shutdown.

- Solvents do not generally need to be degassed. Degas solvents only if the analyte of interest oxidizes easily.
- If the extraction cell cap external O-ring is Viton, do not use acetone.

3.1.2 Filling the Solvent Reservoir

NOTE

When using an ASE 200 Solvent Controller, disregard this section and follow the instructions in the Solvent Controller manual.

1. Fill the solvent reservoir with prepared solvent and set it inside the ASE 200 solvent reservoir compartment (see Figure 2-1).



Use only Dionex solvent reservoirs (1-liter, P/N 045900; 2-liter, P/N 045901). These are glass reservoirs with a plastic, shatterproof coating. Make sure the pressure applied to the reservoirs does not exceed 0.07 MPa (10 psi).

2. Insert the outlet line extending from the underside of the reservoir cap assembly into the reservoir (see Figure 3-1). Make sure that the in-line filter rests on the bottom of the reservoir. This prevents air from being drawn through the line. If needed, gently pull on the outlet line to bring more tubing into the reservoir.

3 • Operation and Maintenance

3. Make sure that the solvent level in the reservoir is below the gas inlet line (see Figure 3-1). This prevents solvent from coming into contact with pneumatic valves.
4. Hand-tighten the lock ring cap securely over the stopper.
5. When refilling the reservoir, remove the cap and stopper and remove the reservoir from the compartment. It is not necessary to disconnect the inlet and outlet lines.

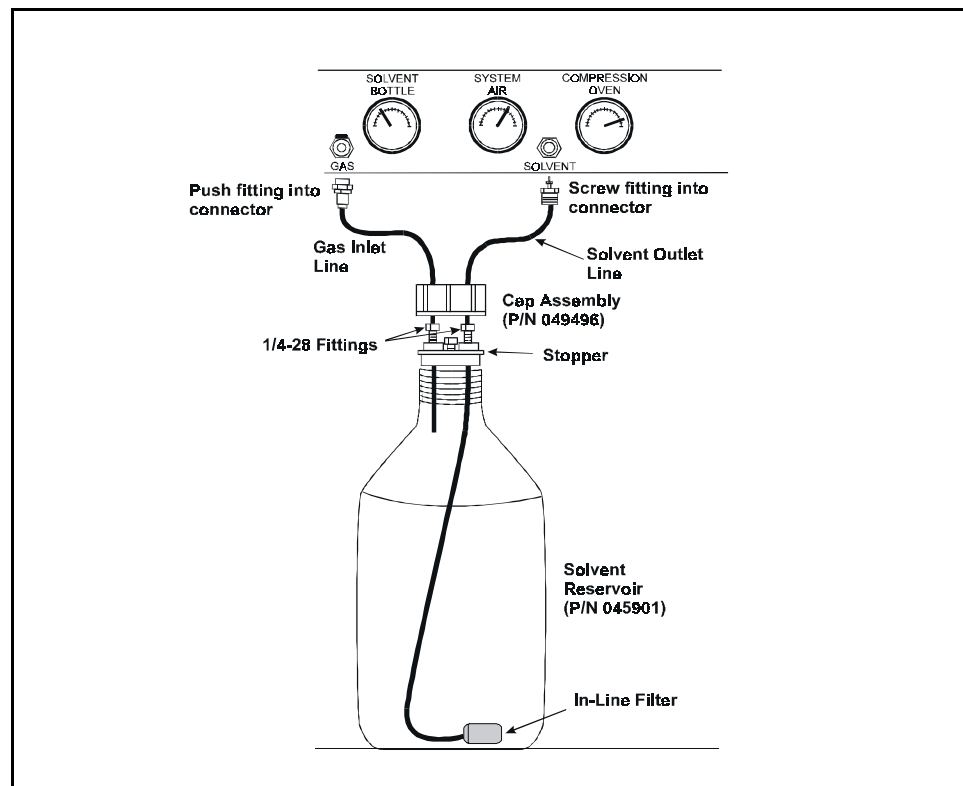

Figure 3-1. Solvent Reservoir Connections

3.1.3 Sample Preparation

Some samples must be mixed with a drying or dispersing agent before being loaded into the cells. If you have successfully followed a particular sample pretreatment procedure for another extraction method, continue using this procedure. However, if you are preparing a new sample or have never run an extraction, follow the guidelines below.

Drying or Dispersing Agent Selection Guidelines

- Two drying and dispersing agents are referred to in the section that follows: sodium sulfate (Na_2SO_4) and pelletized diatomaceous earth (DE). Of these, DE is easier to work with because it dries samples more quickly, provides a cleaner transfer of the mixtures to the cell, and extracts well. Although sodium sulfate is more readily available, it tends to clump the samples, making transfer more difficult.
- The use of sodium sulfate with very wet samples (30% moisture) can result in clogging of the frits in the cell with recrystallized sodium sulfate, particularly if a mixed solvent with acetone is used. In these cases, use DE as a drying agent and mix it with the sample before loading into the extraction cell. (Alternately, DE can be used as a drying agent in the cell in place of sodium sulfate for all levels of moisture.)
- For very wet samples, regardless of which drying agent is used, you must add sodium sulfate to the vials after collection and then pass the extracts through a drying column or drying cartridge to dry the extract completely. At the temperatures used during ASE 200 extractions, more water is co-extracted than with other extraction procedures. To ensure good analyte recovery, thoroughly rinse the sodium sulfate from the vial and cleanup column.
- Never use sodium sulfate with polar extraction solvents, such as methanol. At the temperatures used during

ASE 200 extractions, polar solvents are dissolved by sodium sulfate.

Sample Preparation Guidelines

The following mixtures are recommendations only; adjust the proportions as required.

- If the sample appears dry, use one of these mixtures:
 - 4 grams sample to 1 gram DE
 - 4 grams sample to 4 grams Na₂SO₄
- If the sample appears wet, use one of these mixtures:
 - 4 grams sample to 2 grams DE
 - 4 grams sample to 8 grams Na₂SO₄
- If the sample is pure liquid, use 5 grams sample to 3 grams DE

Mix the sample and the DE or Na₂SO₄ thoroughly in a small vial, beaker, or mortar.

3.1.4 Cell Selection and Filling

Five cell sizes are available: 1 mL, 5 mL, 11 mL, 22 mL, and 33 mL. The cell size does not affect the extraction time, but it does determine how much solvent is used; because the cell is filled with solvent during the extraction, larger cells require more solvent. In addition, a cell that is partially filled with sample requires more solvent than a full cell.

In general, when choosing a cell size:

- Select the smallest cell that holds enough sample to produce accurate extraction results.
- Take into account any drying or dispersing agents, because these increase the volume of the sample.
- When preparing the sample, make sure that the drying or dispersing agent and sample are thoroughly mixed.

Cell Filters

A disposable filter is installed in the cell before sample is loaded. The filter prevents blockage of the stainless steel frit in the bottom cap. Cellulose filters are available for all cell sizes. In addition, glass-fiber filters are available for 11 mL, 22 mL, and 33 mL cells.

Glass-fiber filters are typically used for aqueous extractions, where cellulose may provide inadequate filtration or may be a source of interference with the analytical technique.

Installation of the filters requires a special tool. The tool for the 11 mL, 22 mL, and 33 mL cells is included in the ASE 200 Ship Kit. The other tools must be ordered separately. Use the same tool for both cellulose and glass-fiber filters.

Cell Size	Filter Insertion Tool
1 mL	P/N 055396
5 mL	P/N 055397
11 mL, 22 mL, 33 mL	P/N 049495

To insert the filter:

IMPORTANT

Always hand-tighten the bottom cell cap onto the cell body before installing the filter. Do not place the filter in the bottom cap before installing the cap; this creates an improper seal and allows leaks.

NOTE

It may be helpful to use the Dionex logo and serial number etched on the cell body to identify the direction of fluid flow. For example, designate the end closer to the logo and serial number as the top, and then follow that convention when installing the filter and loading cells into the tray. If you prefer, use a marking pen to draw an arrow on the cell to indicate the direction of flow.

1. Unscrew the top cap from the cell body.
2. Place a cellulose filter (P/N 049458, box of 100) or glass-fiber filter (P/N 047017, box of 100) in the cell at a slight angle, as shown here:



3. Position the insertion tool over the filter:



4. Slowly push the insertion tool into the cell:



5. Make sure the filter is in full contact with the cell:



To fill the cell:

1. Load the sample into the cell, being careful to keep the threads clean on the cell body and cap. This prevents thread fouling and extends the life of the cell.
2. If desired, fill any void volume in the cell with an inert material, such as Ottawa sand (Fisher S23-3). This reduces the amount of solvent used during the extraction.
3. Screw the top cap onto the cell body and hand-tighten. Do not use a wrench or other tool to tighten the cap.

IMPORTANT

Hand-tighten the cell caps. The use of a wrench or other tool can damage the cell.

3 • Operation and Maintenance

4. Check the end of each cap to verify that the white O-rings are in place and in good condition (see Figure 3-2). If an O-ring is discolored or has a hole size of less than 0.5 mm, replace it.

Remove worn O-rings with a small flathead screwdriver. Place the new O-ring over the opening in the end of the cell cap and press it into place, using the tool (P/N 049660) provided in the Ship Kit.

IMPORTANT

Do not attach any labels to the cell. The cells fit snugly in the oven during the extraction process and a label may cause misalignment. In addition, the high temperatures used during extraction can damage the label. For sample identification, reference the Dionex serial number etched on the cell or write on the cell body with a marking pen.

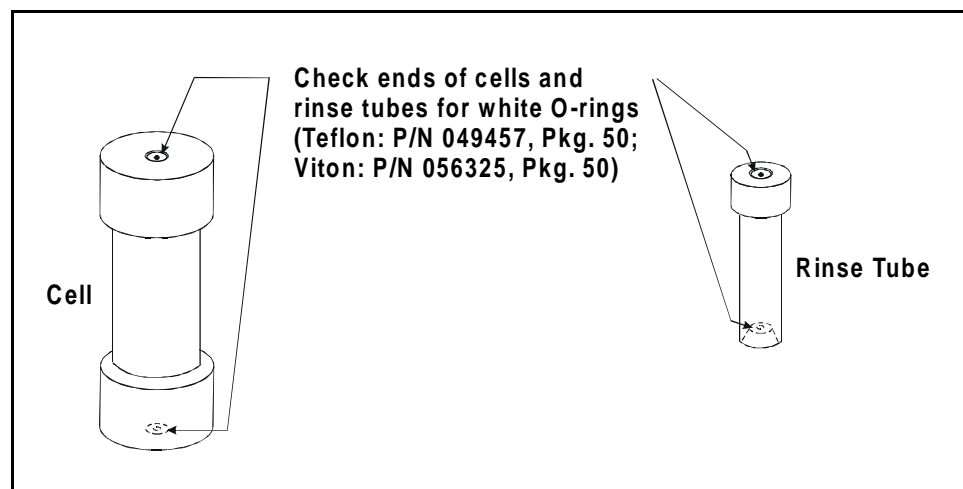

Figure 3-2. O-Ring Inspection

To load the cell tray:

1. Begin loading filled cells into the tray slots in numerical order. Hang the cells vertically in the tray slots from their top caps (the bottom cap contains the cellulose filter). The cells can be mixed on the tray in any order.

In its default control mode (method mode), the ASE 200 begins running at cell 1 and vial 1 and continues until completing the entire tray (if it is full) or until reaching an empty vial or cell slot. An empty slot indicates the end of the run and the ASE 200 stops. For greater flexibility, create a schedule of runs. Section 3.2 describes method and schedule modes in detail.



To avoid injury, exercise caution when the tray is in motion.

2. Check the end of each rinse tube to verify that the O-rings are in place and in good condition (see Figure 3-2). If an O-ring is discolored or has a hole size of less than 0.5 mm, replace it.

Remove worn O-rings with a small flathead screwdriver. Place the new O-ring over the opening in the end of the cell cap and press it into place, using the tool (P/N 049494) provided in the Ship Kit.

3. Load the rinse tubes into the four open slots between cell positions 1 and 24, 6 and 7, 12 and 13, and 18 and 19.

3.1.5 Vial Selection and Loading

Select the vial size according to the size of the cell:

- For 1 mL cells, use 40 mL vials
- For 5 mL cells, use 40 mL vials
- For 11 mL cells, use 40 mL vials
- For 22 mL cells, use 60 mL vials
- For 33 mL cells, use 60 mL vials

Vial Labeling

During the extraction process, sensors determine if a vial is present, contains 1 mL of solvent, or is full. Therefore, vial labels must be placed so that they do not block areas of the vial read by the sensors. Figure 3-3 shows where to attach a label, or to write an identification name or number, so that the identification does not block the sensors.

To remove the vial tray:

Remove the vial tray only when the ASE 200 is idle. (The LED on the left of the **Start** button is lighted when the ASE 200 is idle.)

Grasp the center handle and lift straight up to clear the tray from its support base. Remove the tray from the instrument.

To reinstall the vial tray:

Center the tray over the support base until it slips into place on the support platter.

(Optional) Turn the tray manually (in either direction) until you hear a click, indicating that the tray is locked into the correct position.

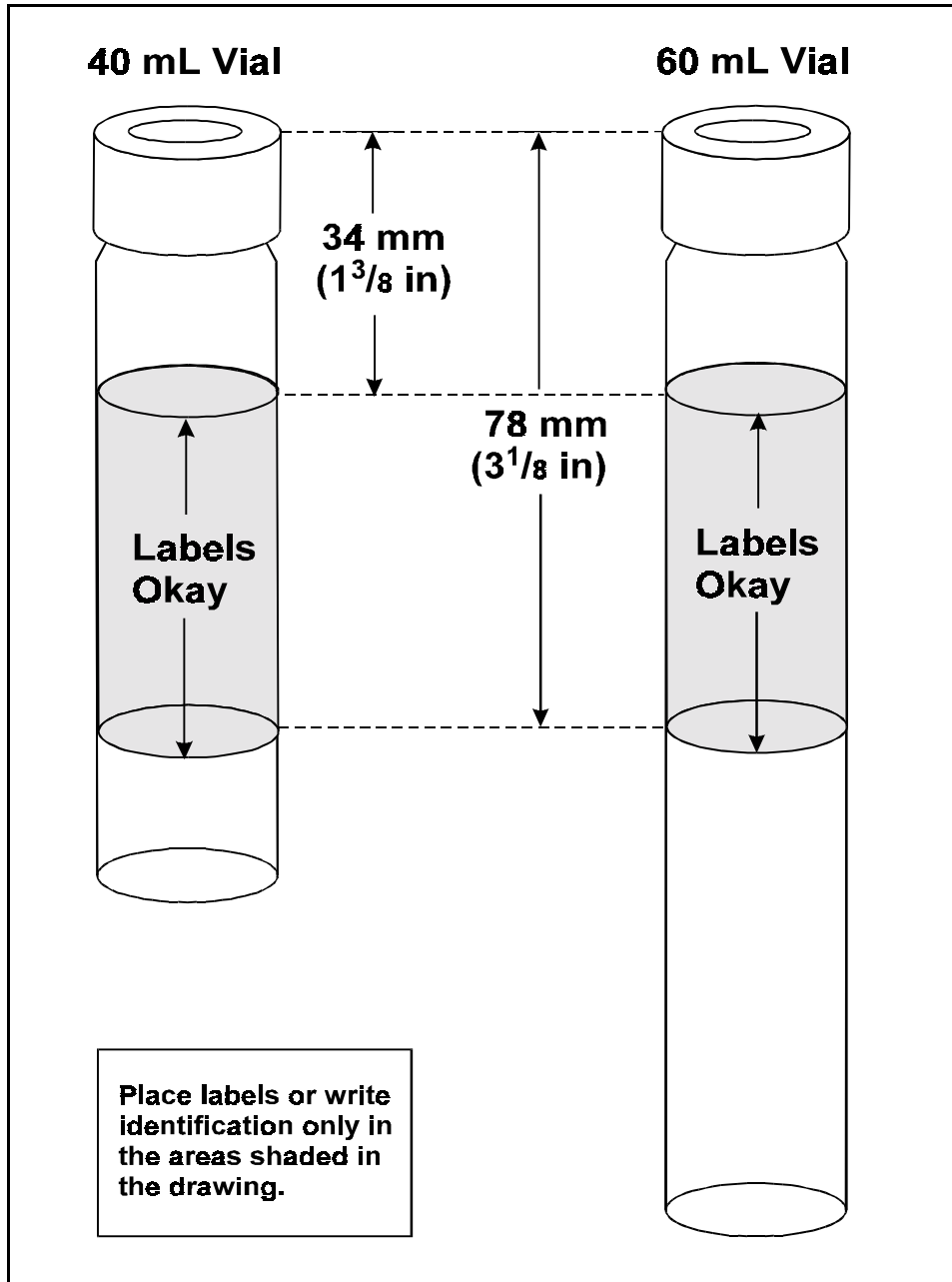

Figure 3-3. Acceptable Vial Label Locations
(Vials shown actual size)

To load the vials:

Follow these guidelines when loading vials into the tray:

- When using the regular 40 mL vials, place tray inserts (P/N 049348) into the vial tray slots to adapt them for the shorter vials. When using graduated 40 mL vials, place vial spacers (P/N 055444) into the vial tray slots. The 60 mL vials do not require either inserts or spacers.
 - When running under method control, for each sample cell loaded, load a collection vial into the corresponding vial tray position. For example, if positions 1 through 10 contain sample cells, load vials in positions 1 through 10.
 - When running under schedule control, load the vials as programmed in the schedule. (See Section 3.2 for a description of method and schedule modes.)
 - When mixing cell sizes, be sure to match the collection vial size to the cell size.
1. Load four vials (40 mL or 60 mL) into the rinse slots (labeled R1 through R4). If available, use the 60 mL vials, to increase the rinse collection capacity.

IMPORTANT

Check rinse vials after each series of runs, and empty if needed before starting the next series.

2. Check that all loaded vials are at a uniform height and that the caps extend above the tray slots. If necessary, remove or add tray inserts or spacers.
3. Make sure the vial sizes match the size of the loaded sample cells (see Section 3.1.5).

IMPORTANT

If the vial and cell sizes are mismatched, the sample will abort.

3.1.6 Rinsing/Priming the System

Pressing the **Rinse** button on the keypad starts a manual rinse, or prime, cycle. During the cycle, the cell tray rotates to the nearest rinse tube, the vial tray rotates to a rinse position, and approximately 4 mL of solvent is pumped through the system.

Run a rinse cycle at the following times:

- After initial setup

NOTE

When running with an ASE Solvent Controller, the system automatically rinses with 8 mL of solvent when the **Start button is pressed. The rinse is also 8 mL if the schedule calls for a change of solvent.**

- After the ASE 200 has been shut down for more than a day, or when there are bubbles in the solvent lines
- After refilling the solvent reservoir
- After changing solvents (rinse twice to remove all of the old solvent)

To set up the ASE 200 to automatically run a rinse between sample extractions, see Section 3.1.7.

3.1.7 Automatic Rinsing Between Samples

An automatic rinse cycle can run between sample extractions. The automatic rinse cycle is identical to the manual rinse cycle (see Section 3.1.6), except that only 1 mL of solvent is pumped through the system during an automatic rinse cycle.

- When running under method control, you can set up the ASE 200 to run an automatic rinse cycle after each sample extraction (see the steps below).
- When running under schedule control, you must specify on each line in the schedule whether an automatic rinse cycle is performed (see Section 3.2.3).

To set up automatic rinses during method control:

1. Verify that rinse tubes and vials are in place and that the vials are empty. Use 60 mL vials, if available, because they provide more rinse collection capacity.
2. Press **Menu** to display the **MENU OF SCREENS** and press **5** to display the **MODULE SETUP** screen.
3. Move the cursor to the **METHOD RINSE** field and press a **Select** button to toggle the field to **ON** (see Figure 3-4). Press **Enter** or a cursor arrow button. A rinse cycle is then performed after each sample extraction run. Method rinse remains the default until toggled off from the **MODULE SETUP** screen.

```

MODULE SETUP
SOLVENT SELECT: NO      MODE: LOCAL
SCRN BACKLIGHT: HIGH   DATE: 950823
KEY SOUND: ON          TIME: 133415
ERROR SOUND: ON        METHOD RINSE: ON
PRESSURE UNITS: PSI    DETAIL SCREEN: 20
BYPASS HEAT-UP: NO    REDUCE RELIEF: NO
Prompt

```

Figure 3-4. Module Setup Screen (Method Rinse On)

3.1.8 Operation with an External Device

An external sample preparation device (such as a device equipped with a robotic arm) can be interfaced to the ASE 200 to perform these tasks:

- Access collection vials containing sample processed by the ASE 200, *or*
- Insert cells into the ASE 200 cell tray and/or remove cells from the cell tray

When interfaced with an external device, the ASE 200 can operate in one of two modes:

- In the *fixed time mode*, operation is based on a specified time period.
- In the *TTL mode*, operation is based on synchronization of TTL start and stop signals.

For more information about these operating modes, refer to the following sections.

External Device Operation: Fixed Time Mode

To operate in the fixed time mode, the user must specify the vial tray and/or cell tray position and the length of time each tray remains immobile. While the trays are immobile, the external device accesses the sample cells and/or extraction vials. At the end of the specified time, the ASE 200 goes on to perform the next extraction in the entered method or schedule.

Specify the operating conditions:

1. To specify the operating conditions for the fixed time mode, press **Menu** to display the **MENU OF SCREENS** and press **9** to display the **EXTERNAL DEVICE INTERFACE** screen (see Figure 3-5).

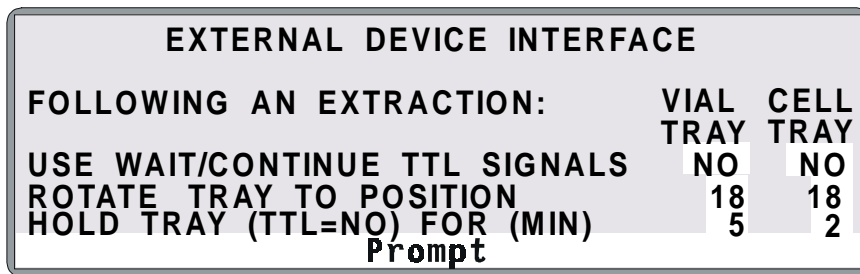

Figure 3-5. External Device Interface Screen:
Fixed Time Mode

2. Make sure the **USE WAIT/CONTINUE TTL SIGNALS** fields are set to **NO**.
3. Follow the steps below to determine which tray position the external device can access; this varies, depending on the device design.
 - a. Check the method or schedule to see which tray position is specified initially.
 - b. Make sure the tray is in position one. Press the **Trays** button to release the tray, and then rotate it manually until the external device can access the position initially specified in the method or schedule.

- c. Check to see which tray position is now in the home position. Move the cursor to the **ROTATE TRAY TO POSITION** field for the tray(s) to be accessed by the external device and enter this number. Press **Enter** or a cursor arrow button.

NOTE

Do not enter vial tray positions 1 through 7 or 20 through 24; the ASE 200 enclosure blocks access to these positions.

NOTE

The ASE 200 automatically increments the tray position with each extraction. For example, if you select tray position 26 to make vial 10 accessible for extraction 1, the ASE 200 will automatically move to vial 11 for extraction 2.

4. Move the cursor to the **HOLD TRAY FOR** field and enter the number of minutes that the tray remains immobile. Be sure to allow enough time for the external device to perform its function and then move clear of the trays before the ASE 200 goes on to the next extraction. Press **Enter** or a cursor arrow button.



CAUTION

If the specified time is too short, the ASE 200 may attempt to move a tray while it is being accessed by the external device.

5. This completes the setup for operation in the fixed time mode.

External Device Operation: TTL Mode

In the TTL mode, wait/continue TTL signals are used to control rotation of the vial tray and/or cell tray. After each extraction, the ASE 200 sends a TTL output signal to the external device and then waits for the device to send a TTL signal. When the ASE 200 receives the TTL signal sent by the device, it goes on to the next extraction in the method or schedule.

Specify the operating conditions:

1. To specify the operating conditions for the TTL mode, press **Menu** to display the **MENU OF SCREENS** and press **9** to display the **EXTERNAL DEVICE INTERFACE** screen (see Figure 3-6).

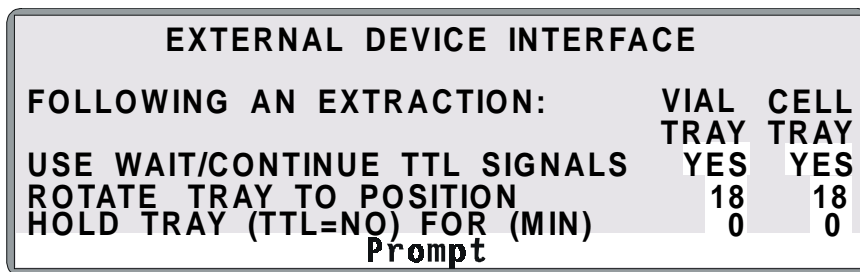

Figure 3-6. External Device Interface Screen: TTL Mode

2. Move the cursor to the **USE WAIT/CONTINUE TTL SIGNALS** field for the tray(s) to be accessed by the external device and select **YES**. Press **Enter** or a cursor arrow button.
3. Follow the steps below to determine which tray position the external device can access; this varies, depending on the device design.
 - a. Check the method or schedule to see which tray position is specified initially.

- b. Make sure the tray is in position one. Press the **Trays** button to release the tray, and then rotate it manually until the external device can access the position initially specified in the method or schedule.
- c. Check to see which tray position is now in the home position. Move the cursor to the **ROTATE TRAY TO POSITION** field for the tray(s) to be accessed by the external device and enter this number. (Do not enter zero, which disables operation of the external device interface feature.) Press **Enter** or a cursor arrow button.

NOTE

Do not enter vial tray positions 1 through 7 or 20 through 24; the ASE 200 enclosure blocks access to these positions.

NOTE

The ASE 200 automatically increments the tray position with each extraction. For example, if you select tray position 26 to make vial 10 accessible for extraction 1, the ASE 200 will automatically move to vial 11 for extraction 2.

4. Make sure zero is entered in the **HOLD TRAY FOR** fields, to disable operation in the fixed time mode. Go on to the next section to make the TTL connections.

Make the TTL connections:

1. The TTL/relay connector strip is located on the CPU card, behind the upper door (see Figure B-15). To open the door, pull on the tab located to the right of the main power actuator (see Figure 2-2).

Each 2-pin connector on the strip includes a signal pin (+) and a ground (-) pin. The ASE 200 Ship Kit includes twisted pairs of wires (P/N 043598) and eight 2-pin connector plugs (P/N 921019).

3 • Operation and Maintenance

2. Attach a 2-pin connector plug to both ends of each pair of wires to be connected. Strip the ends of the wires, insert into the plug, and use a screwdriver to tighten the locking screw. The signal wire goes on the top of each plug; the ground wire goes on the bottom of the plug.
3. Connect these plugs to the TTL connectors on the ASE 200 and the external device as needed. Route the wires through the service chase to the external device (see Figures B-15 and B-16). (Check the external device user's manual for connector details.)

TTL input 1 controls movement of the collection vial tray and TTL input 2 controls movement of the cell tray. Figure 3-7 shows the setup required for the external device to access both trays.

4. Check the polarity of each connection. Be sure to connect signal wires to signal (+) pins and ground wires to ground (-) pins (see Figure 3-7).

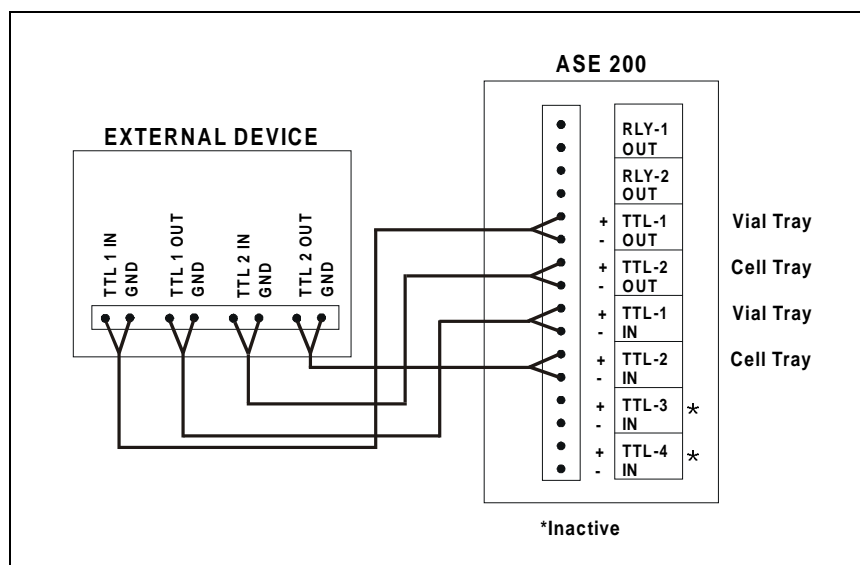
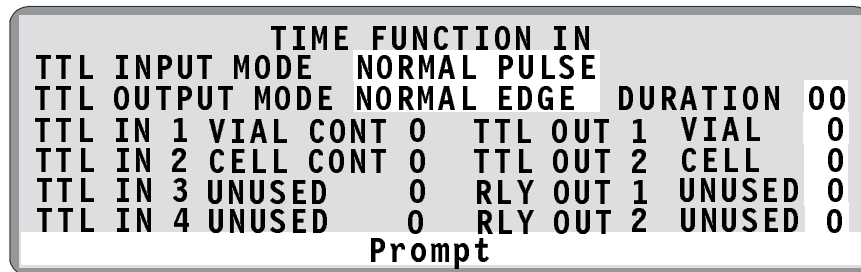

Figure 3-7. TTL Connections to an External Device

5. If necessary, remove wires from the 2-pin plugs and reinsert them in the correct positions. To remove the plugs from the connector strip, pull them straight out.
6. Press **Menu** to display the **MENU OF SCREENS** and press **8** to display the **TIME FUNCTION IN** screen (see Figure 3-8).



TIME FUNCTION IN									
TTL	INPUT	MODE	NORMAL		PULSE				
TTL	OUTPUT	MODE	NORMAL	EDGE	DURATION	00			
TTL	IN 1	VIAL	CONT	0	TTL	OUT 1	VIAL	0	
TTL	IN 2	CELL	CONT	0	TTL	OUT 2	CELL	0	
TTL	IN 3	UNUSED	0		RLY	OUT 1	UNUSED	0	
TTL	IN 4	UNUSED	0		RLY	OUT 2	UNUSED	0	

Prompt

Figure 3-8. Time Function In Screen

7. Move the cursor to the **TTL INPUT MODE** field and select the mode that matches the signal type output by the external device. (Check the external device user's manual for the signal type.) Press **Enter** or a cursor arrow button.

NOTE

The ASE 200 TTL inputs respond to four types of device output signals; see Appendix E for details.

8. When each extraction is complete and the vial is in position for processing, the ASE 200 will send an output signal to the external device. Move the cursor to the **TTL OUTPUT MODE** field and specify the mode for this TTL signal. Press **Enter** or a cursor arrow button.
9. Move the cursor to the **DURATION** field and specify the TTL output pulse duration. (Check the external device user's manual for the signal duration values.) If no value is entered, the default setting (100 milliseconds) remains in effect. Press **Enter** or a cursor arrow button.
10. Go on to the next section to test the system configuration.

Test the system configuration:

1. Press **Menu** to display the **MENU OF SCREENS** and press **8** to display the **TIME FUNCTION IN** screen.
2. To verify the setup for the collection vial tray, move the cursor to the **TTL OUT 1 VIAL** field on the **TIME FUNCTION IN** screen (see Figure 3-9). Select **1** and then press **Enter** or a cursor arrow button. The external device should respond when it receives the TTL signal.

TIME FUNCTION IN									
TTL	INPUT	MODE	NORMAL	PULSE					
TTL	OUTPUT	MODE	NORMAL	EDGE	DURATION				
TTL	IN 1	VIAL	CONT	0	TTL	OUT 1	VIAL		00
TTL	IN 2	CELL	CONT	0	TTL	OUT 2	CELL		1
TTL	IN 3	UNUSED		0	RLY	OUT 1	UNUSED		0
TTL	IN 4	UNUSED		0	RLY	OUT 2	UNUSED		0

Prompt

Figure 3-9. Time Function In Screen: Testing TTL Mode

3. To verify the setup for the cell tray, move the cursor to the **TTL OUT 2 CELL** field on the **TIME FUNCTION IN** screen (see Figure 3-9). Select **1** and then press **Enter** or a cursor arrow button. The external device should respond when it receives the TTL signal.
4. If the external device fails to respond to a TTL signal, do the following:
 - Check that the TTL connections are correctly made.
 - Check that the correct TTL input mode is selected.
 - Using a digital voltmeter, verify that the ASE 200 is sending a +5 V signal.
5. This completes the setup for operation in the fixed time mode.

3.2 Methods and Schedules

NOTE

The following sections describe how to create custom methods and schedules from the ASE 200 front panel. To get started quickly, without creating a new method, run the default method (see Section 3.4.1). For instructions on how to use AutoASE software to create methods and schedules, refer to the AutoASE manual.

Each sample extraction occurs according to a predefined set of operating parameters, or *method*. A method specifies the cell heating time, oven temperature, cell pressure, etc. The ASE 200 can store up to 24 methods.

When running a series of extractions, you can run each sample using the same method (method control), or customize the series by defining a *schedule* of runs (schedule control). A schedule specifies the method to run on each sample in the schedule, the sample cell assigned to each collection vial, and the rinse status after each sample run. The ASE 200 can store up to 24 schedules.

Table 3-1 summarizes methods and schedules and the control modes:

Feature	Description
Method	Defines the operating parameters for a single extraction run (oven temperature, time, pressure, amount of solvent flush, purge time, and, if an ASE 200 Solvent Controller is in use, the solvent types and concentrations).
Schedule	Defines parameters for a series of extraction runs (cell sequence, method to run on each cell, rinse status).
Method control	Runs the same method on each sample loaded in the tray. The series of runs starts with cell position 1 and vial position 1 and proceeds sequentially until all samples are extracted.
Schedule control	Runs a series of extractions according to the schedule definition.

Table 3-1. Methods and Schedules Summary

3.2.1 Creating Methods

Table 3-2 describes each method parameter. Refer to Section 3.2.2 for example methods and Section 3.3 for method development guidelines.

1. Press **Menu** to display the **MENU OF SCREENS** and press **3** to display the **METHOD EDITOR**. If you are opening the screen for the first time after power-up, the screen displays the default method parameters (see Figure 3-10). Thereafter, the screen displays the last method that was edited (if any) or the default parameters (if there is no previous method).

METHOD	EDIT#		SAVE TO	
PREHEAT	0	min C	PRESSURE	1500 psi
HEAT	5	min	TEMPERATURE	100 C
STATIC	5	min	SOL A OTHER	100%
FLUSH%	60	vol	SOL B OTHER	0%
PURGE	60	sec	SOL C OTHER	0%
CYCLES	1		SOL D OTHER	0%
Prompt				

Figure 3-10. Method Editor Screen (Default)

2. To display the default parameters, verify that the cursor is in the **EDIT#** field and enter zero.
3. To create a method, move the cursor to each highlighted field to be changed and enter the desired value. After entering a new value, save it by pressing **Enter** or by pressing a cursor arrow button.

ASE 200 Operator's Manual

Parameter	Function	Value Range													
PREHEAT	Amount of time the cell sits in the oven, being preheated, before solvent is introduced.	0 to 99 min (default=0)													
	The state of the purge valve during the PREHEAT period. (This unlabeled field is to the right of the PREHEAT field.)	C=closed, O=open (default=C)													
HEAT	Amount of time allowed for the sample to reach thermal equilibrium. The duration of the initial heat-up step depends on the method's temperature set point. Set the set point to 0 only when the heat-up period is not required to achieve complete recovery of analytes.	5 to 9 min													
	<table border="1"> <thead> <tr> <th>Set Point (°C)</th> <th>Heat-up Time (Minutes)</th> </tr> </thead> <tbody> <tr> <td>0 (off)</td> <td>0</td> </tr> <tr> <td>40-100</td> <td>5</td> </tr> <tr> <td>101-125</td> <td>6</td> </tr> <tr> <td>126-150</td> <td>7</td> </tr> <tr> <td>151-175</td> <td>8</td> </tr> <tr> <td>176-200</td> <td>9</td> </tr> </tbody> </table>	Set Point (°C)	Heat-up Time (Minutes)	0 (off)	0	40-100	5	101-125	6	126-150	7	151-175	8	176-200	9
Set Point (°C)	Heat-up Time (Minutes)														
0 (off)	0														
40-100	5														
101-125	6														
126-150	7														
151-175	8														
176-200	9														
STATIC	Static solvent extraction time.	0 to 99 min (default=5)													
FLUSH%	Amount of solvent to flush through the cell following the static heating step, expressed as a percentage of the cell volume. For example, if FLUSH =50%, 0.5 mL is flushed through a 1 mL cell, 2.5 mL is flushed through a 5 mL, and so on.	0 to 150% vol in 5% increments (default=60)													
PURGE	Amount of time nitrogen gas purges the cell.	0 to 300 sec (default=60)													
CYCLES	Number of times to perform the static heating and flushing steps. When more than one cycle is specified, the flush % volume is divided among the cycles (see Example Method 1 on page 3-30).	1 to 5 (default=1)													

Table 3-2. Method Editor Parameters

3 • Operation and Maintenance

Parameter	Function	Value Range
TEMPERATURE	Temperature at which to heat the cell. The temperature also determines the duration of the initial heat-up step.	0, 40 to 200 °C (0=off, default=100)
PRESSURE	Amount of fluid pressure in the cell during extraction. The pressure is maintained by the pump.	500 to 3000 psi (default=1500) 3.45 to 21 MPa (default=10.34) 34 to 204 atm (default=102.1) 34 to 207 bar (default=103.4)
SOL A SOL B SOL C SOL D	The solvent type and concentration used for the extraction. Unless an ASE 200 Solvent Controller is in use, this information is for report purposes only and these fields may be left blank.	5 to 100% in 5% increments (default=100% of solvent A); solvent types are listed on page 3-28

Table 3-2. Method Editor Parameters (continued)

- After entering the desired parameters, move the cursor to the **SAVE TO** field. Enter a new (unused) method number, or press **Select Δ** to display the next unused method number. Press **Enter** to save the method.

NOTE

To restore the default method parameters, move the cursor to the **EDIT#** field and press **Delete**.

When the cursor is in the **SAVE TO** field, pressing **Select Δ** cycles through the available method numbers. For example, if methods 1 and 3 already exist, pressing **Select Δ** displays 2, the next unused number. Pressing

Select Δ again displays 4, the next unused number. Press **Enter** to save the method under the desired number.

Entering Solvent Types and Percentages

The **METHOD EDITOR** screen lists some of the most common solvents for extractions. From the list, select the type(s) and percentage of solvent(s) used in each method. If the solvent is not listed, select **OTHER**.



Do not use solvents with an autoignition point of 40 to 200 °C. If you have a question about solvent suitability, contact Dionex.

When an ASE 200 Solvent Controller is in operation, these selections determine the solvent type and amount delivered by the Solvent Controller to the ASE 200. If the Solvent Controller is not present and configured, this information appears in the report printout (see Section 3.6), but has no effect on the extraction.

To select a solvent type:

1. Move the cursor to the **SOL A** field and press **Select** Δ or **Select** ∇ to scroll through the list of solvents. The following solvents are listed:

Acetone	Hexane	MeCl ₂	Toluene
Acetonitrile	iso-Octane	Pet Ether	Water
Chloroform	iso-Propanol	PERC	Water/Acid
Ethanol	Methanol	THF	Other

2. After selecting the type, press the right cursor arrow to go to the **%** field and enter the percent concentration. If you enter 100% in this field, the percentages for the other three solvents are reset to zero.

3. If the solvent is a mixture of two or more types, enter the other solvent types and percentages in the **SOL B**, **SOL C**, and/or **SOL D** fields. Make sure the total for all solvents is equal to 100%.

Editing Methods

After creating a method, you can modify it by changing parameter values. Either save the changes to the existing method number, or save the altered method to a new method number and preserve the original method.

1. Display the **METHOD EDITOR** screen. In the **EDIT#** field, enter the number of the method to be edited (1-24), or press **Select** Δ to scroll through the numbers of previously stored methods.

To display the default method parameters, enter zero.

2. After selecting the method number, press **Enter**. The method's defined parameters appear.
3. To change a parameter value, move the cursor to the field and enter the new value. This deletes the previous value. Table 3-2 lists the values allowed for each parameter.
4. When changes are complete, move the cursor to the **SAVE TO** field. Press **Enter** to save the changes to the current method number, or select a new method number and press **Enter**.

3.2.2 Example Methods

Example Method 1

Figure 3-11 illustrates the **METHOD EDITOR** screen for Example 1.

METHOD EDIT #		SAVE TO	3
PREHEAT	1 min 0	PRESSURE	1500 psi
HEAT	5 min	TEMPERATURE	75 C
STATIC	5 min	SOL A	Methanol 100%
FLUSH%	40 vol	SOL B	Other 0%
PURGE	90 sec	SOL C	Other 0%
CYCLES	3	SOL D	Other 0%
Prompt			

Figure 3-11. Example Method 1

When run, the method proceeds as follows:

- The oven begins heating to 75 °C.
- When the oven reaches the set point, the vial and cell are loaded. A **PREHEAT** period of 1 minute begins and the purge valve opens.
- At the end of the **PREHEAT** period, the pump fills the cell with solvent. The static valve closes and the pump continues pumping until the pressure reaches 1500 psi.
- The initial 5-minute heat step occurs, followed by the first 5-minute static step.
- After the static step, the static valve opens and the pump flushes 13% of the cell volume of fresh solvent through the cell. This amount is approximately one-third of the total of 40% to be flushed through in the three cycles.
- The static and flush cycles repeat two more times.
- The method then continues to a 90-second purge step.

To create Example Method 1:

1. Press **Menu** to display the **MENU OF SCREENS** and press **3** to display the **METHOD EDITOR**.
2. With the cursor positioned in the **EDIT#** field, enter zero to display the default method parameters.
3. Move the cursor to the following fields and enter the given values:

PREHEAT	1 min	
PURGE VALVE	O	
FLUSH %	40 vol	
CYCLES	3	
PRESSURE	1500 psi	
TEMPERATURE	75 °C	
SOL A	Methanol	100%
PURGE	90 sec	

4. Move the cursor to the **SAVE TO** field and enter 3 for the new method. Press **Enter**.

Example Method 2

Figure 3-12 illustrates the **METHOD EDITOR** screen for Example 2.

METHOD EDIT#			SAVE TO	2
PREHEAT	1 min	0	PRESSURE	1500 psi
HEAT	6 min		TEMPERATURE	125 C
STATIC	10 min		SOL A	Acetone 50%
FLUSH%	70 vol		SOL B	Hexane 45%
PURGE	60 sec		SOL C	Other 5%
CYCLES	1		SOL D	Other 0%
Prompt				

Figure 3-12. Example Method 2

When run, the method proceeds as follows:

- The oven begins heating to 125 °C.
- When the oven reaches the set point, the vial and cell are loaded. A **PREHEAT** period of 1 minute begins and the purge valve opens.
- At the end of the **PREHEAT** period, the purge valve closes and the pump fills the cell with solvent. The static valve closes and the pump continues pumping until the pressure reaches 1500 psi.
- An initial 6-minute heat step occurs, followed by a 10-minute static step.
- After the static step, the static valve opens and the pump flushes 70% of the cell volume of fresh solvent through the cell.
- The method then continues to the 60-second purge step.

Example Method 3

Figure 3-13 illustrates the **METHOD EDITOR** screen for Example 3.

METHOD EDIT #		SAVE TO	1
PREHEAT	0 min	PRESSURE	2000 psi
HEAT	7 min	TEMPERATURE	150 C
STATIC	5 min	SOL A	Acetone 50%
FLUSH%	50 vol	SOL B	MeC12 50%
PURGE	60 sec	SOL C	Other 0%
CYCLES	2	SOL D	Other 0%
Prompt			

Figure 3-13. Example Method 3

When run, the method proceeds as follows:

- The oven begins heating to 150 °C.
- When the oven reaches the set point, the vial and cell are loaded. The pump fills the cell with solvent. The static valve closes and the pump continues pumping until the pressure reaches 2000 psi.
- An initial 7-minute heat step occurs, followed by the first 5-minute static step.
- After the static step, the static valve opens and the pump flushes 25% of the cell volume of fresh solvent through the cell. This amount is one-half of the total of 50% to be flushed through in the two cycles.
- The static and flush steps are repeated. The method then continues to the 60-second purge step.

3.2.3 Creating Schedules

1. Press **Menu** to display the **MENU OF SCREENS** and press **4** to display the **SCHEDULE EDITOR**. When the screen is opened for the first time after power-up, it displays the default schedule parameters (see Figure 3-14). Thereafter, the screen displays either the last schedule that was edited (if any) or the default parameters (if there is no previous schedule).

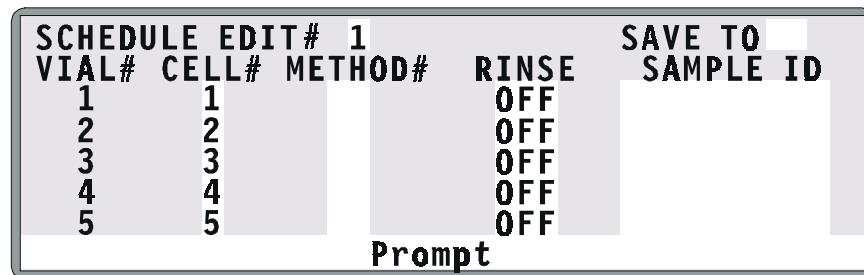

SCHEDULE EDIT#	1	SAVE TO		
VIAL#	CELL#	METHOD#	RINSE	SAMPLE ID
1	1		OFF	
2	2		OFF	
3	3		OFF	
4	4		OFF	
5	5		OFF	

Prompt

Figure 3-14. Schedule Editor Screen (Default)

Each line in the **SCHEDULE EDITOR** represents one sample extraction run. The maximum runs per schedule is 26. A vial number (1 through 26) is permanently assigned to each line in the **SCHEDULE EDITOR**. Corresponding cell numbers are preassigned to each vial, but number assignments are not permanent; you can change the cell number sequence, skip cell numbers, or use the same cell number multiple times. Vial number assignments, however, are permanent.

To scroll through the schedule, press the down arrow button repeatedly. When the cursor reaches the bottom line on the screen, the next line scrolls up.

2. For each line in a schedule, enter the desired schedule information (see Table 3-3).

Schedule Field	Description	Values
CELL	Initially, the cell numbers correspond to the vial numbers (cell 1 is assigned to vial 1, cell 2 is assigned to vial 2, etc.). However, you can enter a different cell number. For example, when performing multiple extractions on the same sample, assign one sample cell to multiple (up to 26) vials (see Example Schedule 3 on page 3-38).	1 through 24
METHOD	Enter the number of the method to run. A different method can be run on each sample. Because the oven heats up faster than it cools down, it is advisable to enter methods in a schedule from coolest to hottest. This minimizes the oven wait time between methods.	1 through 24
RINSE	Specify whether a rinse is performed after each extraction and which solvent is used. When an ASE 200 Solvent Controller is in operation, select ON if the last solvent was a mixture; otherwise, specify the solvent in bottle A, B, C, or D. Initially, this field contains the default value from the MODULE SETUP screen (see Section 3.1.7). Changing this field overrides the setup value.	OFF =no rinse, ON =last solvent used; ON A , ON B , ON C , and ON D =solvent in corresponding bottle
SAMPLE ID	Enter an identification number for the sample (optional).	Up to 10 numeric characters

Table 3-3. Schedule Parameters

3. Move the cursor to the **SAVE TO** field. Enter a number for the new schedule (1-24), or press **Select Δ** to display the next unused schedule number, and then press **Enter** to save.

3.2.4 Example Schedules

Example Schedule 1

Run a different method every six extractions. Do not rinse between extractions.

VIAL#	CELL#	METHOD#	RINSE	SAMPLE ID
1	1	1	OFF	
2	2	1	OFF	
3	3	1	OFF	
4	4	1	OFF	
5	5	1	OFF	
6	6	1	OFF	
7	7	2	OFF	
8	8	2	OFF	
9	9	2	OFF	
10	10	2	OFF	
11	11	2	OFF	
12	12	2	OFF	
13	13	3	OFF	
14	14	3	OFF	
15	15	3	OFF	
16	16	3	OFF	
17	17	3	OFF	
18	18	3	OFF	
19	19	4	OFF	
20	20	4	OFF	
21	21	4	OFF	
22	22	4	OFF	
23	23	4	OFF	
24	24	4	OFF	
25				
26				

To create Example Schedule 1:

1. Press **Menu** to display the **MENU OF SCREENS** and **5** to display the **MODULE SETUP** screen.
2. Verify that the **METHOD RINSE** field is **OFF**. If necessary, move the cursor to the field and press **Select Δ** to toggle to **OFF**. Press **Enter**.
3. Verify that the **MODE** field is **LOCAL**. If necessary, move the cursor to the field and press **Select Δ** to toggle to **LOCAL**. Press **Enter**.
4. Press **Menu** to display the **MENU OF SCREENS** and **4** to display the **SCHEDULE EDITOR**.
5. With the cursor positioned in the **EDIT#** field, enter zero to display the default schedule parameters (see Figure 3-14).
6. In this schedule, the method number is the only parameter that needs to be entered because all others remain at their default values. Move the cursor to the **METHOD#** field and enter 1 for lines 1-6 in the schedule. Enter 2 for lines 7-12, 3 for lines 13-18, and 4 for lines 19-24. Lines 25 and 26 are not used.
7. Move the cursor to the **SAVE TO** field and enter a number for the new schedule. Press **Enter**.

ASE 200 Operator's Manual

Example Schedule 2

Run a different method every six extractions. Run three extractions on the last cell. Rinse between extractions.

Vial#	Cell#	Method#	Rinse	Sample ID
1	1	1	ON	1001
2	2	1	ON	1002
3	3	1	ON	1003
4	4	1	ON	1004
5	5	1	ON	1005
6	6	1	ON	1006
7	7	2	ON	1007
8	8	2	ON	1008
9	9	2	ON	1009
10	10	2	ON	1010
11	11	2	ON	1011
12	12	2	ON	1012
13	13	3	ON	1013
14	14	3	ON	1014
15	15	3	ON	1015
16	16	3	ON	1016
17	17	3	ON	1017
18	18	3	ON	1018
19	19	4	ON	1019
20	20	4	ON	1020
21	21	4	ON	1021
22	22	4	ON	1022
23	23	4	ON	1023
24	24	4	ON	1024
25	24	5	ON	1025
26	24	5	ON	1026

Example Schedule 3

Run three extractions on each cell. Run a different method every six extractions. Rinse between samples.

Vial#	Cell#	Method#	Rinse	Sample ID
1	1	1	OFF	1
2	1	1	OFF	
3	1	1	ON	
4	2	1	OFF	2
5	2	1	OFF	
6	2	1	ON	
7	3	2	OFF	3
8	3	2	OFF	
9	3	2	ON	
10	4	2	OFF	4
11	4	2	OFF	
12	4	2	ON	
13	5	3	OFF	5
14	5	3	OFF	
15	5	3	ON	
16	6	3	OFF	6
17	6	3	OFF	
18	6	3	ON	
19	7	4	OFF	7
20	7	4	OFF	
21	7	4	ON	
22	8	4	OFF	8
23	8	4	OFF	
24	8	4	ON	
25				
26				

3.3 Method Development Guidelines

Follow the procedure below when developing a method for a new sample type:

1. Select a solvent(s) (see Section 3.1.1).
2. Prepare the sample (see Section 4.).
3. Select a cell size (see Section 3.1.4).
4. Create a new method with default operating parameters. To do this, go to the **METHOD EDITOR** screen, position the cursor in the **EDIT#** field, and enter zero to display the default parameters. Move the cursor to the **SAVE TO** field and select a new method number (2, for example). Press **Enter** to save the method.
5. Create a schedule that extracts the same sample three times into separate vials (see the example in Figure 3-15). Specify the method created in Step 4 for each extraction.

SCHEDULE EDIT# 2		SAVE TO 2	
VIAL#	CELL#	METHOD#	RINSE
1	1	2	OFF
2	1	2	OFF
3	1	2	OFF
4			OFF
5			OFF

Prompt

Figure 3-15. Example Schedule for Method Development

6. Run the schedule and analyze the extracts.
7. If target analytes are present in vial 2 or 3, make the following adjustments (one at a time) to the method:
 - a. Raise the temperature. In general, raising the temperature increases the efficiency of the extraction process. However, because compounds can degrade at high temperature, it is best to keep the temperature below the maximum allowed (200 °C). If oxidation is a concern, degas the solvent before use.

- b. Run two static/flush cycles. Extending the static time enhances diffusion of the analytes into the extraction fluid. Separating the static time into two cycles, rather than using one longer cycle, allows the introduction of fresh solvent midway through. The fresh solvent helps maintain a favorable solvent/sample equilibrium for samples that are heavily loaded or otherwise difficult to extract.
- c. Increase the flush volume to allow more solvent to pass through the sample. The flush volume can be up to 150% of the cell volume.

NOTE

To prevent overflowing the 33 mL cells, it may be necessary to balance the number of static cycles and flush volume.

8. After each adjustment, repeat the schedule and analyze the extract. When target analytes no longer appear in the extract from the second vial, the method is complete for this sample type.

NOTE

The ASE 200 uses pressure to maintain the extraction solvents as liquids when the solvents are heated above their boiling points, as well as to fill the extraction cells quickly. Setting the pressure above 13.8 MPa (2000 psi) has little or no effect on analyte recovery.

9. If analytes still appear in the extract from the second vial, make the following adjustments (one at a time) to the method:
 - Run three static/flush cycles.
 - Raise the temperature again.
 - Increase static time.
 - Select a different solvent.

3.4 Running Extractions

3.4.1 Running Under Method Control

Before running an extraction, you must create a method that defines operating conditions for the run. Section 3.2.1 explains how to create methods from the ASE 200 front panel. For instructions on creating methods with AutoASE software, refer to the software manual.

After running, a report of the run can be printed (see Section 3.6). Print the report *before* starting the next run; information about a run is cleared from memory when the next run starts.

A default method is available to enable you to get started running quickly, before creating any custom methods. Before running the default method, assign a method number to it.

To number the default method:

1. Press **Menu** to display the **MENU OF SCREENS** and press **3** to display the **METHOD EDITOR**.
2. With the cursor in the **EDIT#** field, enter zero to display the default parameters (see Figure 3-16).
3. Move the cursor to the **SAVE TO** field; press **Select Δ** to display the next unused method number and press **Enter**. This new method can now be loaded and run.

METHOD	EDIT#		SAVE TO	
PREHEAT	0	min C	PRESSURE	1500 psi
HEAT	5	min	TEMPERATURE	100 C
STATIC	5	min	SOL A OTHER	100%
FLUSH%	60	vol	SOL B OTHER	0%
PURGE	60	sec	SOL C OTHER	0%
CYCLES	1		SOL D OTHER	0%

Prompt

Figure 3-16. Method Editor Screen (Default)

To load a method and start the run:

4. Press **Menu** to display the **MENU OF SCREENS**, and press **Enter** (or **1**) to display the **LOAD METHOD OR SCHEDULE** screen (see Figure 3-17).

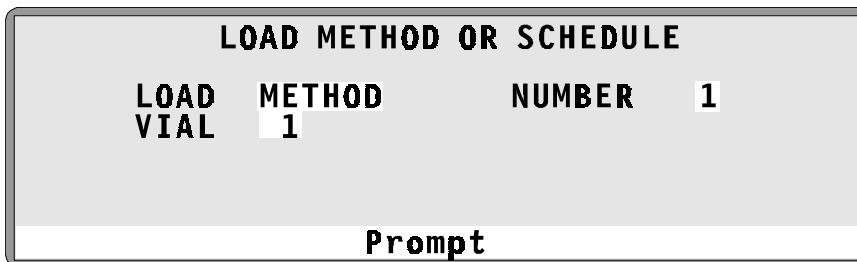

Figure 3-17. Load Method or Schedule Screen

5. Verify that **METHOD** appears in the **LOAD** field. If not, press **Select Δ** to toggle to **METHOD**.
6. By default, the method begins running at vial 1. To start the method run at a different vial, move the cursor to the **VIAL** field and enter the desired number.
7. Move the cursor to the **NUMBER** field and enter the number of the method. Press **Enter** or a cursor arrow. This closes the **LOAD METHOD OR SCHEDULE** screen and opens the **CURRENT STATUS** screen, displaying the method number and the status of other ASE 200 operating parameters (see Figure 3-18).

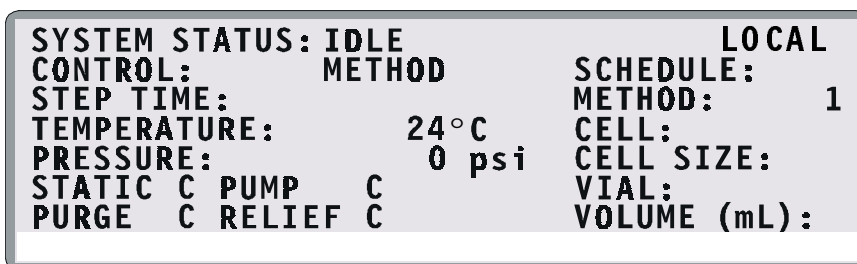

Figure 3-18. Current Status Screen

NOTE

The temperature set point is activated immediately after the method is loaded (before you press **Start**). If the current oven temperature is less than the set point, the oven begins heating.

8. Press **Start** to begin the run. If the oven has not reached the set point, there is a delay while the oven heats up or cools down. During this time, the **STATUS** screen displays **OVEN WAIT**.

When the oven is within 5 °C of the set point, the cell and vial trays rotate to the first positions and the ASE 200 begins running the first sample. During Method control, the ASE 200 runs samples sequentially until it reaches an empty cell or vial slot or, if the trays are full, until all samples have been run and the trays are back at positions 1. See Section 2.2 for details about the extraction process.

During the run, the status of operating parameters is updated on the **CURRENT STATUS** screen. After a set time (the default is 20 minutes), and if no keypad buttons have been pressed, an alternate status screen is displayed (see Figure 3-19). To return to the **CURRENT STATUS** screen, press any button on the front panel keypad.

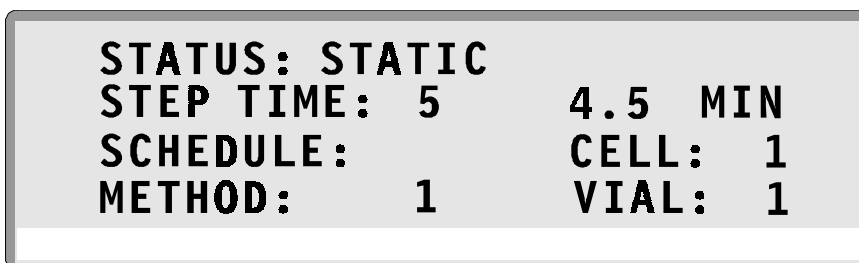

Figure 3-19. Alternate Status Screen

NOTE

To change the time delay for displaying the alternate status screen, or to disable the screen, see Section B.3.

3.4.2 Running Under Schedule Control

1. Press **Menu** to display the **MENU OF SCREENS**, and press **Enter** (or **1**) to display the **LOAD METHOD OR SCHEDULE** screen.
2. Press a **Select** button to toggle to **LOAD SCHEDULE** (see Figure 3-20).

LOAD VIAL	SCHEDULE	NUMBER
1	1	1

Prompt

Figure 3-20. Load Method or Schedule Screen

3. By default, the schedule begins running at vial 1. To start the schedule at a different vial, move the cursor to the **VIAL** field and enter the desired number.
4. Move the cursor to the **NUMBER** field and enter the number of the schedule to be run. Press **Enter** or a cursor arrow. The **LOAD METHOD OR SCHEDULE** screen is closed and the **CURRENT STATUS** screen appears.

NOTE

The temperature set point is activated immediately after the schedule is loaded (before you press **Start). If the current oven temperature is less than the set point, the oven begins heating.**

5. Press **Start**.

The ASE 200 begins the first run according to the parameters selected for the first method in the schedule. When the first extraction run is complete, the ASE 200

proceeds to the next line in the schedule and continues until all scheduled runs are completed.

If the methods used in a schedule have different temperature set points, it causes a delay(s) in the schedule while the oven heats up or cools down. During this time, the **STATUS** screen displays **OVEN WAIT**.

3.4.3 Aborting a Run

Press **Abort** to halt the current run. All valves close, flow stops, and the screen displays the following options:



```
1 Continue with the abort function.  
2 Cancel: return to process.  
3 Abort after current method.
```

Press the numeric button for the desired option (or move the cursor to the option) and press **Enter**.

- 1 Continue with the abort function—cancels the method or schedule. If necessary, a purge is done to remove solvent from the sample. Then, residual pressure is relieved from the system, and the current cell is returned to the tray.
- 2 Cancel: return to process—resumes the run at the point at which the abort button was pressed.
- 3 Abort after current method—cancels the method or schedule after the current run (and rinse, if programmed) is completed.

After a run is aborted, to resume running at the vial at which the run was stopped (rather than restarting at vial 1), enter the starting vial number on the **LOAD METHOD OR SCHEDULE** screen (see Sections 3.4.1 and Section 3.4.2).

3.5 Post-Extraction Procedures

3.5.1 Cleaning the Cells



Cells are extremely hot after an extraction. Allow cells to cool for at least 15 minutes before handling. Be especially cautious with cells that have been heated over 50 °C.

After use, empty the cells and rinse the cell caps and cell bodies with water or organic solvent. For most applications, simply rinsing the end caps is sufficient. If necessary, disassemble the end caps and sonicate or soak in solvent. Cell bodies (but not the caps) can be cleaned in a dishwasher or high-temperature cleaning unit. Do not exceed 400 °C when performing high-temperature cleaning.

Disassemble the end caps and sonicate or soak in solvent. See Section 5.1 for disassembly instructions.

3.5.2 Processing Extracts

The composition of the extracts generated by the ASE 200 is very close to that generated by Soxhlet and other standard liquid extraction techniques when using the same solvent. Use the same analytical method for the ASE extracts that you employed for extracts obtained from other techniques.

NOTE

An external device can be interfaced with the ASE 200 system to automatically process the sample extracts. See Section 3.1.8 for details.

3.6 Printing Reports

NOTE

The ASE 200 prints via a serial port. To print from a printer that is not serial-compatible, install a parallel-serial converter. Contact Dionex for more information.

To print a report of an extraction run, open the **COMMUNICATION** screen by selecting screen **6** from the **MENU OF SCREENS**.

```
COMMUNICATION
AUTOMATIC PRINTOUT OFF
SCHEDULE PRINTOUT 2
PREVIOUS RUN PRINTOUT
COMM PORT TEST
Prompt
```

Figure 3-21. Communication Screen

- To print a report after each run, set **AUTOMATIC PRINTOUT** to **ON** and press **Enter**. Note that the ASE 200 must be in **LOCAL** mode for printing to be activated.
- To print the parameters programmed for a particular method or schedule, select **METHOD** or **SCHEDULE** and enter the number. Press **Enter** to print the report.
- To print a report of the most recent run, move the cursor to the field to the right of **PREVIOUS RUN PRINTOUT** and press **Enter**. The report must be printed before the next run starts because information about a run is cleared from memory when the following run starts.
- To run a test on the communications port and printer connections, move the cursor to the field to the right of **COMM PORT TEST** and press **Enter**. The following test line should print; if it does not, refer to Section 4.5 for troubleshooting information.

The quick brown fox jumps over the lazy dog's back. 0123456789

3.7 Routine Maintenance

This section describes routine maintenance procedures that may be performed by the user. All other maintenance procedures must be performed by Dionex personnel.

3.7.1 Daily Maintenance

- Fill the solvent reservoir, if needed. Run a rinse cycle after filling.
- Empty the waste vial, if needed.
- Empty the rinse vials.
- Check the gases.
- Check for leaks from the solvent reservoir, pump, valves, and other components in the flow path (see Figure 3-22). Wipe up liquids and tighten or replace leaking fittings (see Section 5.2).

3.7.2 Periodic Maintenance

- Replace the external O-rings (P/N 049457, pkg. of 50 Teflon O-rings; P/N 056325, pkg. of 50 Viton O-rings) in the cell caps and rinse tubes approximately every 50 to 75 extractions, or when worn.

NOTE

Viton O-rings are available for high temperature applications, such as dioxins.

- Replace the PEEK seals (P/N 049455, pkg. of 10; P/N 049454, pkg. of 50) inside the cell caps after approximately every 50 to 75 extractions (see Section 5.1).
- Verify that the two needles on the needle mechanism are straight. See Section 5.7 for replacement instructions.
- Replace the septa in the rinse vials.

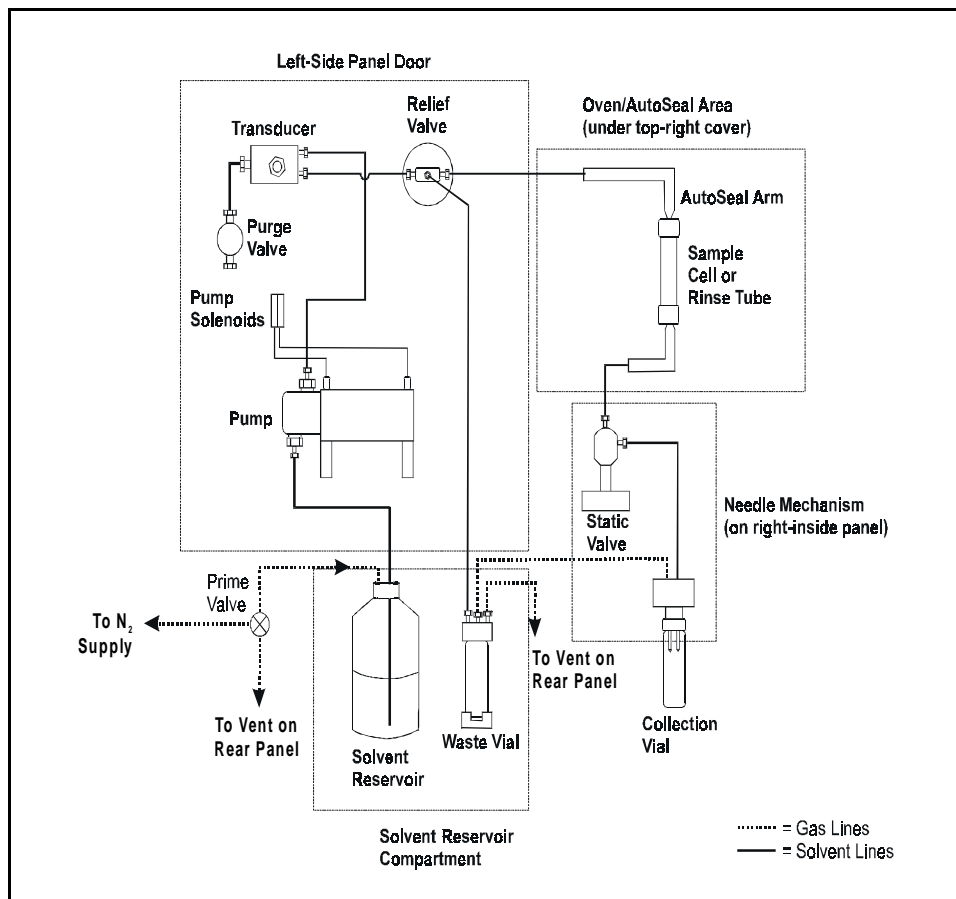

Figure 3-22. Solvent Flow Schematic

3.8 Shutdown

- If the solvent is 100% organic, simply turn off the power for overnight shutdown.
- If the solvent contains acids or other strong additives, rinse the system with a 100% organic solvent or with distilled water before overnight shutdown.
- For longer shutdowns, also turn off the gas and compressed air supplies.
- Before shipping the ASE 200, empty all solvent bottles and reconnect them to the system. Then run one or more rinse cycles to remove solvent from the lines.

NOTE

If there is no input to the ASE 200 for four hours (no control panel buttons are pressed and no commands are received from AutoASE software), the oven is automatically shut off.

ASE 200 Operator's Manual

4 • Troubleshooting

This chapter is a guide to troubleshooting problems that may occur while operating the ASE 200 Accelerated Solvent Extractor. Turn to the section that best describes the operating problem. There, possible causes of the problem are listed in order of probability, along with the recommended courses of action.

If the screen displays an error message, check the list of error messages for possible causes.

If you are unable to eliminate a problem, contact Dionex. In the U.S., call 1-800-346-6390 and select the Technical Support option. Outside the U.S., call the nearest Dionex office.

4.1 Error Messages

When an error occurs, an error message is displayed on the screen. The message remains until you press a key to clear it, or until it is replaced by another error message. Each message is identified by a number in the lower-right corner of the screen.

The **ERROR LOG** screen lists all errors that occurred during a given run. The screen also identifies the cell and vial number in use when the error occurred. See Section C.3 for details.

- **212 You forgot to save your method after editing it. Press ENTER again to abandon it permanently or press any other key to finish editing this method.**

Cause: After editing a method, but before saving the editing changes, you tried to load a different method.

Action: If you do not want to save the editing changes, press **Enter** to retain the method in its previously saved version.

Action: If you want to continue editing the method, press any key. When you finish editing, move the cursor to the

SAVE TO field and press **Enter** to save the changes to the current method number. To save the changes to a different number, move the cursor to the **SAVE TO** field and enter a new (unused) method number, or press **Select** Δ to display the next unused method number. Press **Enter** to save the method.

- **224 You forgot to save your method after editing it. Press MENU again to abandon it permanently or press any key other than ENTER to finish editing the method.**

Cause: After editing a method, but before saving the editing changes, you pressed the **Menu** button to exit the **METHOD EDITOR** screen.

Action: If you do not want to save the editing changes, press **Menu** again to retain the method in its previously saved version.

Action: If you want to continue editing the method, press any key. When you finish editing, move the cursor to the **SAVE TO** field and press **Enter** to save the changes to the current method number. To save the changes to a different number, move the cursor to the **SAVE TO** field and enter a new (unused) method number, or press **Select** Δ to display the next unused method number. Press **Enter** to save the method.

- **248 The instrument is in REMOTE mode. Put the instrument in LOCAL mode to use this function.**

Cause: When the ASE 200 is in **REMOTE** mode, some functions are disabled and only three keypad buttons are functional: **Trays**, **Rinse**, and **Abort**.

Action: Press **Menu** to display the **MENU OF SCREENS** and press **5** to display the **MODULE SETUP** screen. Move the cursor to the **MODE** field and press a **Select** button to toggle the field to **LOCAL** (see Figure 3-4). Press **Enter** or a cursor arrow button.

- **300 You pressed an incorrect key for this entry.**

Cause: You pressed an invalid key, unexpected for this entry.

Action: Enter an acceptable value. Table 3-2 lists the values allowed for method parameters. Table 3-3 lists the values allowed for schedule parameters.
- **301 Detected an error in the database.**

Cause: The memory in which the database is stored has become corrupted.

Action: Contact Dionex for assistance.
- **302 There is an ASE function in progress. Please wait for function to complete.**

Cause: The function in progress must occur by itself, or else cannot occur at the same time as the function you attempted to initiate.

Action: Wait until the function in progress is completed before pressing a front panel button or making an entry on the screen.
- **303 A valid schedule has not been selected.**

Cause: You selected a nonexistent schedule number to run.

Action: Enter a valid schedule number in the **NUMBER** field of the **LOAD METHOD OR SCHEDULE** screen.

- **304 There is an error in the composition of the schedule line.**

Cause: The line references a nonexistent method or a method that contains an error. If the error is in line 1 of the schedule, this message appears when the schedule is loaded. Otherwise, the schedule begins running, but stops when it reaches the schedule line with the error.

Action: Check all lines in the schedule. Enter a valid method number and/or correct the error in the method. Table 3-2 lists the values allowed for method parameters. Table 3-3 lists the values allowed for schedule parameters

- **305 The oven will not come up to temperature.**

Cause: The heater cable connection to the power supply is loose, or there is a problem with a heater component.

Action: Open the upper door. The power supply is on the left. Check the heater cable plugged into the 4-pin connector on the power supply; if the cable is plugged in firmly, the problem is with an internal heater component. Contact Dionex for assistance.

- **306 Time-out on flush portion of the method.**

Cause: The pump could not deliver the specified flush volume before the time-out expired. The cell or lines may be plugged.

Action: Rinse the system to ensure that the pump and valves are clear. If the rinse runs successfully, the cell may be plugged. Clean or replace the stainless steel cell frit (see Section 5.1) and replace the cellulose or glass-fiber filter (see Section 3.1.4). Then, mix the sample with a dispersing agent (see Section 3.1.3) and run the extraction again.

If the rinse is not successful, the solvent lines may be plugged. Contact Dionex for assistance.

- **307 Time-out condition in loading a collection vial.**

Cause: A collection vial was not in the specified position of the schedule.

Action: Before running a schedule, check that all vials are in place.
- **308 The collection vial is full.**

Cause: The collection vial is full, or the sensor failed to detect it.

Action: Empty the vial. Also, make sure the vial label is not blocking the area read by the sensor. See Figure 3-3 for acceptable vial label locations. If the error message reappears, contact Dionex for assistance.
- **309 Error time-out condition in loading a cell.**

Cause: A cell was not in the specified position of the schedule.

Action: Before beginning a schedule, check that all cells are in place.
- **310 Error time-out condition in unloading a cell.**

Cause: A cell was not in the specified position of the schedule.

Action: Before beginning a schedule, check that all cells are in place.
- **311 The selected method is not valid or a method has not been selected.**

Cause: The selected method is incomplete, or a method was not selected.

Action: If you have not done so already, select a method. If the selected method is invalid, make sure there are no missing steps.

- **312 Solvent does not reach collection vial or rinse vial.**

Cause: The safety time-out expired before the vial sensors detected any solvent in the vial. The cell or lines may be plugged.

Action: After the run, rinse the system to make sure that the pump and valves are clear. If the rinse runs successfully, the cell may be plugged. Clean or replace the stainless steel cell frit (see Section 5.1) and replace the cellulose or glass-fiber filter (see Section 3.1.4). Then, mix the sample with a dispersing agent (see Section 3.1.3) and run the extraction again.

If the rinse is not successful, the solvent lines may be plugged. Contact Dionex for assistance.

- **313 A schedule or method run cannot start because of a safety condition. Check incoming air or vial tray.**

Cause: Air or nitrogen pressures are low.

Action: Check regulator pressures (see Section B.2.4). Check for air leaks (see Section 4.4).

- **314 The needle will not retract.**

Cause: The needle mechanism is disabled.

Action: Check the air pressure. The air source should be between 0.41 and 1.38 MPa (60 and 200 psi); 0.68 MPa (100 psi) is recommended. Check the system air regulator pressure (see Section B.2.4). Check the delivery of air to the needle mechanism. Open the left-side panel door and make sure nothing is blocking the needle mechanism.

- **315 Vial tray will not home.**

Cause: The tray is blocked or disabled, or the sensor is out.

Action: Make sure nothing is physically blocking the tray. Manually check the tray movement. If necessary, contact Dionex for assistance.
- **316 WARNING: Rinse vials are missing or full. Please empty and replace rinse vials. Press ENTER to continue.**

Cause: Rinse vials are not available for use, or are not detected by the vial sensors.

Action: Make sure rinse vials are present in the correct positions (labeled R1, R2, R3, and R4) of the vial tray. If the rinse vials are full, empty or replace them.

Action: Make sure the vial label is not blocking the area read by the vial sensors. See Figure 3-3 for acceptable locations for vial labels. If the error message reappears, contact Dionex for assistance.
- **317 Needle will not engage or a collection vial is not present.**

Cause: A collection vial was not in the specified position of the schedule, or the movement of the needle assembly to the tray is physically blocked.

Action: Before beginning a schedule, check that all vials are in place. Open the left-side panel door and make sure nothing is blocking the needle mechanism.
- **318 Vial will not go to position.**

Cause: The vial tray is incorrectly installed.

Action: Contact Dionex for assistance.

- **319 Collection vial is missing.**

Cause: No collection vial is installed, or the sensors cannot detect the vial.

Action: Make sure a collection vial is installed in the correct position of the vial tray.

Action: Make sure the vial label is not blocking the area read by the sensors. See Figure 3-3 for acceptable locations for vial labels. If the error message reappears, contact Dionex for assistance.

- **320 Vial tray motor logic error condition.**

Cause: The vial tray motor or sensor has malfunctioned.

Action: Contact Dionex for assistance.

- **321 Cell tray will not home.**

Cause: The tray is blocked or disabled, or the sensor is out.

Action: Make sure nothing is physically blocking the tray. Manually check the tray movement. If necessary, contact Dionex for assistance.

- **322 There are no rinse tubes.**

Cause: The cell tray does not contain any rinse tubes.

Action: Install rinse tubes in the four rinse positions in the cell tray.

- **323 Cell tray will not rotate to the correct position.**

Cause: The tray is physically blocked, or the sensor is out of position.

Action: Make sure nothing is physically blocking the tray. Manually check the tray movement. If necessary, contact Dionex for assistance.

- **324 Cell tray motor logic error condition.**

Cause: The cell tray motor or sensor has malfunctioned.

Action: Contact Dionex for assistance.
- **325 The AutoSeal arm will not open.**

Cause: The air supply is not reaching the arm.

Action: Check the air pressure. The air source should be between 0.41 and 1.38 MPa (60 and 200 psi); 0.68 MPa (100 psi) is recommended. Check the system air regulator pressure (see Section B.2.4). Check for air leaks (see Section 4.4).
- **326 There is a cell in the AutoSeal arm.**

Cause: The cell was not returned to the tray.

Action: Remove the cell from the arm and place it in the correct position in the tray.
- **327 The AutoSeal arm will not move to the tray.**

Cause: The air supply is not reaching the arm.

Action: Check the air pressure. The air source should be between 0.41 and 1.38 MPa (60 and 200 psi); 0.68 MPa (100 psi) is recommended. Check the system air regulator pressure (see Section B.2.4). Check for air leaks (see Section 4.4).

Cause: The arm is hitting the cell tray.

Action: The arm is out of alignment. Contact Dionex for assistance.
- **328 No cell present at this position.**

Cause: No cell is installed, or the sensors cannot detect it.

Action: Make sure a cell is installed in the correct position in the tray. If the sensors do not detect the installed cell, contact Dionex for assistance.

- **329 The AutoSeal arm will not move to the oven.**
Cause: The air supply is not reaching the arm.
Action: Check the air pressure. The air source should be between 0.41 and 1.38 MPa (60 and 200 psi); 0.68 MPa (100 psi) is recommended. Check the system air regulator pressure (see Section B.2.4). Check for air leaks (see Section 4.4).
- **331 The entered value for this parameter is not in range. Please re-enter value.**
Cause: The value is too high or too low for this parameter.
Action: Enter an acceptable value. Table 3-2 lists the values allowed for method parameters. Table 3-3 lists the values allowed for schedule parameters.
- **332 Cannot perform the rinse function because another function is in progress.**
Cause: The **Rinse** button functions only when the ASE 200 is idle. (The LED on the left of the **Start** button is lighted when the ASE 200 is idle.)
Action: Wait until the function in progress is completed before pressing the **Rinse** button.
- **333 Cannot engage the tray motors at this time because another function is in progress.**
Cause: The vial tray can be engaged only when the ASE 200 is idle. (The LED on the left of the **Start** button is lighted when the ASE 200 is idle.)
Action: Wait until the function in progress is completed, or press the **Abort** button and select the desired option.

- **334 Cannot start a schedule or method run because another function is in progress.**

Cause: A schedule or method cannot begin while another function is in progress.

Action: Wait until the function in progress is completed, or else press the **Abort** button, select the desired option, and then start the schedule or method.

- **335 Cannot engage or disengage the tray motors because either the vial needle is in place or the AutoSeal arm has a cell at the tray.**

Cause: The vial tray can be engaged or disengaged only when the ASE 200 is idle. (The LED on the left of the **Start** button is lighted when the ASE 200 is idle.)

Action: Wait until the ASE 200 is idle, or else press the **Abort** button and select the desired option.

- **336 Cell pressure has exceeded maximum allowable threshold. The pump has been turned off for safety reasons.**

Cause: There is a blockage in the system. The cell or lines may be plugged, or the static or relief valves may have failed.

Action: Run a rinse cycle. If the rinse runs successfully, the cell may be plugged. Clean or replace the stainless steel cell frit (see Section 5.1) and replace the cellulose or glass-fiber filter (see Section 3.1.4). Next, mix the sample with a dispersing agent such as diatomaceous earth or sand (see Section 3.1.3) and run the extraction again.

If the rinse is not successful, there may be a blockage in the solvent lines, or the static or relief valve may need replacing. Contact Dionex for assistance.

- **337 Possible problem with the Temperature RTD. It appears to be shorted.**

Cause: The temperature display is inconsistent with normal operation.

Action: The RTD (Resistive Temperature Device) should be replaced. Contact Dionex for assistance.
- **338 The large cell size requires the large vial size.**

Cause: The cell size determines the correct vial size; currently, the cell and vial sizes are mismatched.

Action: Use 60 mL vials with both 22 mL and 33 mL cells.
- **339 A process (schedule/method) in progress. Please wait for completion of task.**

Cause: The schedule or method must finish running before a new function is initiated.

Action: Wait until the schedule or method finishes running before pressing a front panel button or making an entry on the screen. Or, cancel the process by pressing the **Abort** button, and then initiate the new task.
- **340 Vial tray has been detected as being absent.**

Cause: The vial tray is missing, is incorrectly installed, or is present but cannot be detected by the sensor.

Action: If the vial tray is not present, install it now.

Action: If the tray is installed, turn it manually (in either direction) until you hear a click, indicating that the tray is locked into the correct position. If the error message reappears, the sensor is malfunctioning. Contact Dionex for assistance.

- **341 Oven nitrogen pressure is low.**

Cause: The nitrogen gas pressure applied to the oven compression system during an extraction is less than the approximately 1.03 MPa (130 psi) that is required.

Action: Check the compression oven gauge in the solvent reservoir compartment (see Figure B-4 in Appendix B); the gauge should read 130 psi. If it does not, adjust the regulator knob for the gauge (see Figure B-5) until the gauge reads 130 psi.

Action: Adjust the pressure regulator on the nitrogen supply to 0.97 to 1.38 MPa (140 to 200 psi).

Action: If the nitrogen supply is low, replace it.

Action: If there is any drift in the electronics, they must be recalibrated. Contact Dionex for assistance.

- **342 Solvent vapor threshold exceeded.**

Cause: There may be a leak in the cell.

Action: Tighten the cell caps (hand-tighten only). Check for foreign material on the threads of the cap, seal surface, and cell body. If necessary, replace the O-rings (see Figure 3-2) and/or the PEEK seals (see Section 5.1).

Cause: Solvent may not be completely removed from the cell during the purge cycle (especially with 33 mL cells).

Action: Increase the purge time (see Section 3.2.1).

Cause: There may be a leak in the system.

Action: Open the left-side panel door and visually inspect the following fittings for leaks (see Figure 4-3): pump check valves, pump fittings, solvent line fittings, transducer fittings, relief valve fittings, and static valve fittings. Tighten or replace any leaking fittings (see Section 5.2).

- **343 Internal leak into pan threshold exceeded. Please correct problem and press any key to continue.**

Cause: There is a leak in the solvent flow path.

Action: Open the left-side panel door and visually inspect the following fittings for leaks (see Figure 4-3): pump check valves, pump fittings, solvent line fittings, transducer fittings, relief valve fittings, and static valve fittings. Tighten or replace any leaking fittings (see Section 5.2).

- **344 Pump cavitation: Check solvent bottle for solvent. There may be a leak or other pump-related problem.**

Cause: The solvent reservoir is empty.

Action: Refill the solvent reservoir with a prepared solvent.

Cause: A defective cell cap O-ring is allowing leakage.

Action: Replace the external O-rings (P/N 049457, pkg. of 50 Teflon O-rings; P/N 056325, pkg. of 50 Viton O-rings). Replace the O-rings approximately every 50 to 75 extractions, or when worn.

Cause: There may be air in the lines.

Action: Check all air lines.

- **345 System air pressure has dropped below a safe level. Restore air pressure and press any key to continue.**

Cause: The **SYSTEM AIR PRESSURE** is the pressure from the compressed air source. This reading should be approximately equal to the reading on the pressure gauge labeled **AIR** behind the lower door (see Figure B-4 on page B-9).

Action: Adjust the pressure regulator for the air supply to 50 psi.

Action: If the error message appears again, the electronics may need to be recalibrated. Contact Dionex for assistance.

- **346 Total solvent percentage should be equal to 100% to run.**

Cause: You attempted to run a method in which the total for all solvents does not equal 100%. This may be an older method, written before the introduction of the ASE 200 Solvent Controller.

Action: Adjust the percentages in the method so that the total for all solvents equals 100%, save the method, and restart the run.

Cause: AutoASE downloaded a method in which the total of the selected solvents does not equal 100%.

Action: Adjust the percentages in the method so that the total for all solvents equals 100%, save the method, and restart the run.

Cause: The total solvent percentage in the method equals 100%, but memory is corrupted.

Action: Contact Dionex for assistance.

- **347 The instrument is in REMOTE mode. Put the instrument in LOCAL mode to modify this entry.**

Cause: In some cases, the ASE 200 must be in **LOCAL** mode before you can enter a value on the screen or press a **Select** button to toggle a field between parameters.

Action: Press **Menu** to display the **MENU OF SCREENS** and press **5** to display the **MODULE SETUP** screen. Move the cursor to the **MODE** field and press a **Select** button to toggle the field to **LOCAL** (see Figure 3-4). Press **Enter** or a cursor arrow button.

- **348 The instrument is in REMOTE mode. Put the instrument in LOCAL mode to use this function.**

Cause: In some cases, the ASE 200 must be in **LOCAL** mode before you can operate a particular feature.

Action: Press **Menu** to display the **MENU OF SCREENS** and press **5** to display the **MODULE SETUP** screen. Move the cursor to the **MODE** field and press a **Select** button to toggle the field to **LOCAL** (see Figure 3-4). Press **Enter** or a cursor arrow button.

- **349 You forgot to save your method after editing it. Press ENTER again to abandon it permanently or press any other key to finish editing this method.**

Cause: You tried to load a new method before saving changes to the method currently being edited.

Action: If you do not want to save the editing changes, press **Enter** to abandon them and retain the method in its previously saved version. If you want to continue editing the method, press any key. When you finish editing, you have two options:

To save the changes to the current method number, move the cursor to the **SAVE TO** field and press **Enter**.

To save the changes to a different method number, move the cursor to the **SAVE TO** field and enter a new (unused) schedule number, or press **Select** Δ to display the next unused method number. Press **Enter** to save the method.

- **350 You forgot to save your method after editing it. Press MENU again to abandon it permanently or press any other key to continue editing the method.**

Cause: You pressed **Menu** before saving changes to the method currently being edited.

Action: If you do not want to save the editing changes, press **Menu** again. This retains the method in its

previously saved version. If you want to continue editing the method, press any key. When you finish editing, you have two options:

To save the changes to the current method number, move the cursor to the **SAVE TO** field and press **Enter**.

To save the changes to a different method number, move the cursor to the **SAVE TO** field and enter a new (unused) method number, or press **Select** Δ to display the next unused method number. Press **Enter** to save the method.

- **351 You forgot to save your schedule after editing it. Press ENTER again to abandon it permanently or press any other key to finish editing this schedule.**

Cause: You tried to load a new schedule before saving changes to the schedule currently being edited.

Action: If you do not want to save the editing changes, press **Enter**. This retains the schedule in its previously saved version. If you want to continue editing the schedule, press any key. When you finish editing, you have two options:

To save the changes to the current schedule number, move the cursor to the **SAVE TO** field and press **Enter**.

To save the changes to a different schedule number, move the cursor to the **SAVE TO** field and enter a new (unused) schedule number, or press **Select** Δ to display the next unused schedule number. Press **Enter** to save the schedule.

- **352 You forgot to save your schedule after editing it. Press MENU again to abandon it permanently or press any other key to continue editing the schedule.**

Cause: You pressed **Menu** before saving changes to the schedule currently being edited.

Action: If you do not want to save the editing changes, press **Menu** again to abandon them and retain the schedule

in its previously saved version. If you want to continue editing the schedule, press any key. When you finish editing, you have two options:

To save the changes to the current schedule number, move the cursor to the **SAVE TO** field and press **Enter**.

To save the changes to a different schedule number, move the cursor to the **SAVE TO** field and enter a new (unused) schedule number, or press **Select** Δ to display the next unused schedule number. Press **Enter** to save the schedule.

- **353 Method cannot be saved if total solvent percentage is not equal to 100%. Check solvent percentage for error.**

Cause: You attempted to save a method in which the total of selected solvents is less than or greater than 100%.

Action: Adjust the percentages so that the total for all solvents equals 100% and then save the method.

- **354 Hydrocarbon sensor reading is low. Recalibrate hydrocarbon baseline. Hydrocarbon sensor may need to be replaced.**

Cause: The hydrocarbon level is significantly lower than expected.

Action: Calibrate the hydrocarbon sensor at the earliest opportunity. Refer to Section 5.9 for calibration instructions.

Action: If the error message reappears, replace the hydrocarbon sensor. Refer to Section 5.10 for instructions on how to install a new sensor.

- **355 WARNING ONLY: Hydrocarbon sensor reading is low. Recalibrate hydrocarbon baseline, using diagnostic screen.**

Cause: The hydrocarbon level is lower than expected.

Action: Calibration of the hydrocarbon sensor is recommended at this time, but is not required. If you do not calibrate the sensor now, there is a risk that a subsequent run may be aborted unexpectedly. Refer to Section 5.9 for calibration instructions.

- **356 Time-out condition in rotating the collection vial for external interface.**

Cause: A collection vial was not in the specified position before the time-out expired. The collection vial tray is physically blocked, or the electronics have malfunctioned.

Action: Turn off the power. Make sure nothing is physically blocking the tray. Manually check the tray movement. Turn on the power and resume operation.

Action: If the error message reappears, the electronics have malfunctioned. Contact Dionex for assistance.

- **357 Conflicting entry: Either the vial position is zero or TTL is enabled.**

Cause: To have an external device access sample from the collection vial tray, you must specify a non-zero tray position and disable the TTL signals.

Action: Press **9** on the **MENU OF SCREENS** to display the **EXTERNAL DEVICE INTERFACE** screen. If necessary, move the cursor to the **ROTATE VIAL TRAY TO POSITION** field and enter a new (non-zero) position. If necessary, move the cursor to the **USE WAIT/CONTINUE TTL SIGNALS** field and select **NO**. Press **Enter** or a cursor arrow button to save the editing changes.

- **358 Time-out condition in rotating the cell tray for external interface.**

Cause: A cell was not in the specified position before the time-out expired. The cell tray is physically blocked, or the electronics have malfunctioned.

Action: Turn off the power. Make sure nothing is physically blocking the tray. Manually check the tray movement. Turn on the power and resume operation.

Action: If the error message reappears, the electronics have malfunctioned. Contact Dionex for assistance.

- **359 Conflicting entry: Either the cell position is zero or TTL is enabled.**

Cause: To have an external device access the cell tray, you must specify a non-zero tray position and disable the TTL signals.

Action: Press **9** on the **MENU OF SCREENS** to display the **EXTERNAL DEVICE INTERFACE** screen. If necessary, move the cursor to the **ROTATE TRAY TO POSITION** field and enter a new (non-zero) position. If necessary, move the cursor to the **USE WAIT/CONTINUE TTL SIGNALS** field and select **NO**. Press **Enter** or a cursor arrow button to save the changes.

4.2 System Stopped

- **Method or schedule complete**

Check the display screen for error messages. If no messages are displayed, the ASE 200 probably stopped because the method or schedule run was complete.

During Method control, the ASE 200 runs samples sequentially until it reaches an empty cell or vial slot or, if the trays are full, until all samples have been run and the trays are back to positions 1.

During Schedule control, the ASE 200 runs according to each line defined in the schedule. A schedule is complete when no more lines are defined.

- **Electrical cables improperly installed**

Open the left-side panel door and the upper-front door. Check that all electrical cables are seated properly in the connectors on the printed circuit boards.

- **Valve driver card problem**

1. Open the left-side panel door.
2. Check the LEDs on the valve driver card (the PC board at the top of the left-side panel door). If the ASE 200 completed at least one run and is now idle, the LEDs at positions D15, D17, and D23 should be lighted (see Figure 4-1).
3. Turn the power off and then back on. The LEDs at positions D15, D17, and D23 should be lighted. If any other lights are on, there may be a problem with the card. Contact Dionex for assistance.

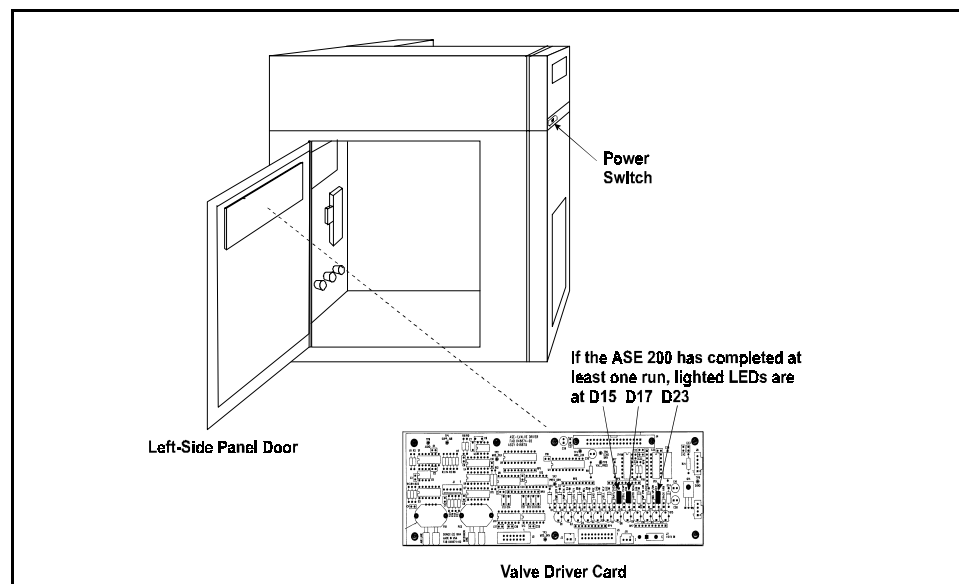

Figure 4-1. Valve Driver Card LEDs

4.3 Liquid Leaks

- **Missing or worn-out cell or rinse tube O-rings**

Check the ends of the cell or rinse tube for white O-rings (P/N 049457, pkg. of 50). If an O-ring is discolored or has a hole size of less than 0.5 mm, replace it (see Figure 4-2).

Remove worn O-rings with a small flathead screwdriver. Place the new O-ring over the opening in the end of the cell cap and press it into place, using the tool (P/N 049660) provided in the Ship Kit.

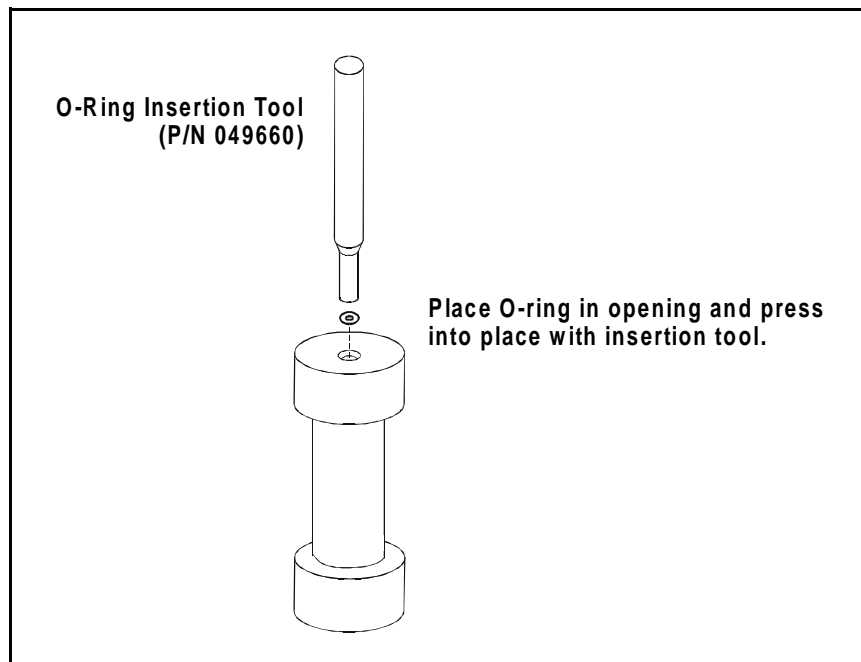

Figure 4-2. O-Ring Installation

- **Worn-out cell PEEK seal**

Replace the seal (see Section 5.1).

- **Leak in solvent flow path**

Open the left-side panel door and visually inspect the following fittings for leaks (see Figure 4-3): pump check valves, pump fittings, solvent line fittings, transducer fittings, relief valve fittings, and static valve fittings. Tighten or replace any leaking fittings (see Section 5.2).

If the pump head is leaking, replace the piston seals (see Section 5.4).

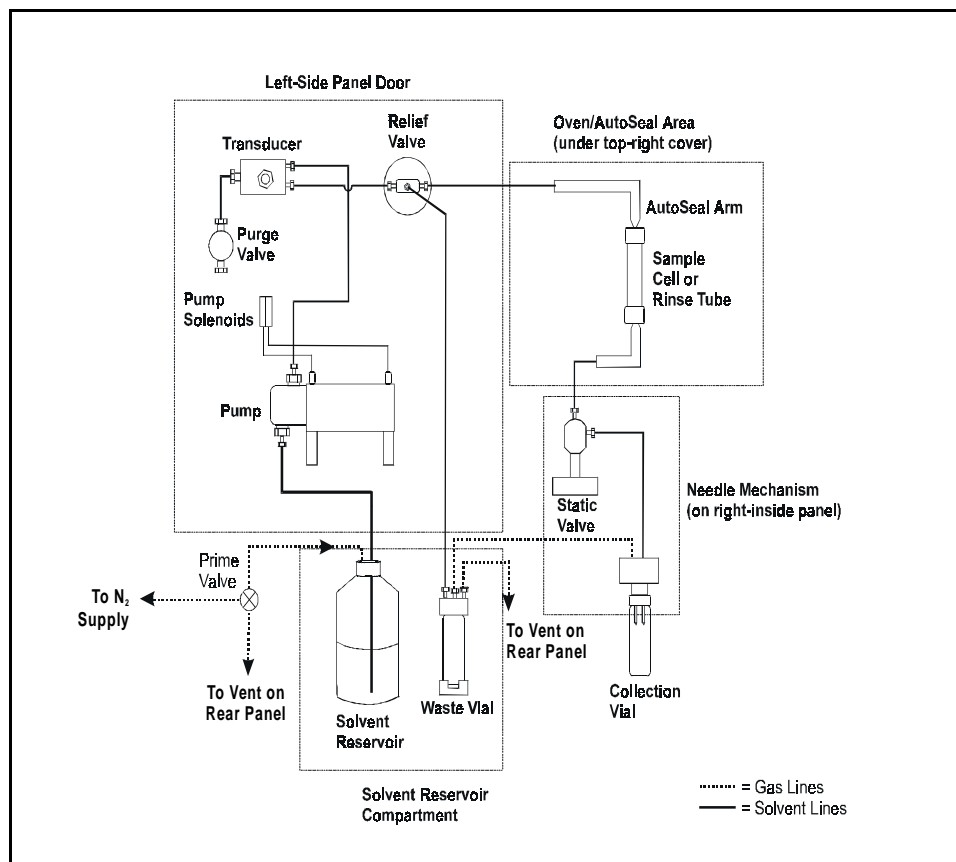

Figure 4-3. Solvent Flow Schematic

- **Leaking into waste vial during static cycle**

Fluid dripping into the waste vial when the cell is under pressure and the static valve is closed indicates a dirty or worn relief valve (see Section 5.5).

- **Leaking into collection vial during static cycle**

Check the source needle tip in the collection vial. This is the slightly longer needle, closest to the rear of the ASE. Fluid dripping into the collection vial from the source needle during the static cycle indicates a dirty or worn static valve (see Section 5.6).

4.4 Gas/Air Leaks

Gas/air leaks are usually audible and frequently cause excessive gas/air consumption.

Look for leaks at the air/gas supply, the rear panel, the solvent reservoir compartment, and the interior connections. Open the left-side panel door for access to the interior connections. Listen for leaks and/or run your hand over the area to feel the escaping gas.

If you find any loose connections, push the tubing firmly onto its fitting. If the fitting or tubing continues to leak, replace it.



Do not open the door while running an extraction.

4.5 Reports Do Not Print

- **Printer connections incorrect**

Display the **COMMUNICATIONS** screen (press **Menu** and **6**). Move the cursor to the **COMM PORT TEST** entry field and press **Enter**. The following test line should print:

```
The quick brown fox jumps over the lazy dog's back. 0123456789
```

If the test line does not print, check the printer connections (see Section 4.). Verify that the printer port is a serial port (or that a parallel-serial converter is installed, if you are trying to print from a parallel printer). If the connections are correct, refer to the printer manual for troubleshooting information.

- **Automatic printout option set to off**

Set the **AUTOMATIC PRINTOUT** field on the **COMMUNICATIONS** screen to on.

- **Attempting to print after starting the next run**

Because information about the previous run is cleared from memory when the next run starts, you must print the report before starting the next run.

5 • Service

This chapter describes routine service procedures for the ASE 200 that users may perform. Any service procedure not described here must be performed by Dionex personnel.

NOTES

The ASE 200 electronics are not customer-serviceable. All repairs involving electronics components must be performed by Dionex personnel.



The CPU card contains a lithium battery. If the CPU card is replaced, dispose of the used battery according to the manufacturer's instructions.

Before replacing any part, refer to the troubleshooting information in Chapter 4 to isolate the cause of the problem. When ordering replacement parts, please include the ASE 200 model number and serial number. To contact Dionex in the U.S., call 1-800-346-6390. Outside the U.S., call the nearest Dionex office.

Substituting non-Dionex parts may impair ASE 200 performance, thereby voiding the product warranty. See the warranty statement in the Dionex Terms and Conditions for more information.

5.1 Replacing the Cell PEEK Seal and Teflon O-Ring

A worn PEEK seal is deeply grooved and fails to form a tight seal between the cell cap and body during extractions, causing leaks.

Refer to Figure 5-1 for cell assembly components and part numbers.

1. Unscrew the cap from the cell body.
2. Use the snap ring tool (P/N 049493) provided in the Ship Kit to remove the snap ring from the cell cap. Insert the pointed ends of the tool into the two holes in the snap ring and squeeze the handles of the tool together to release the tension on the ring. While continuing to squeeze the handles, pull the ring out of the cap. When it is out, carefully release the handles of the tool and remove the ring from the tool.
3. Remove the cap insert. Also remove the PEEK seal, which fits into a groove in the bottom of the insert.

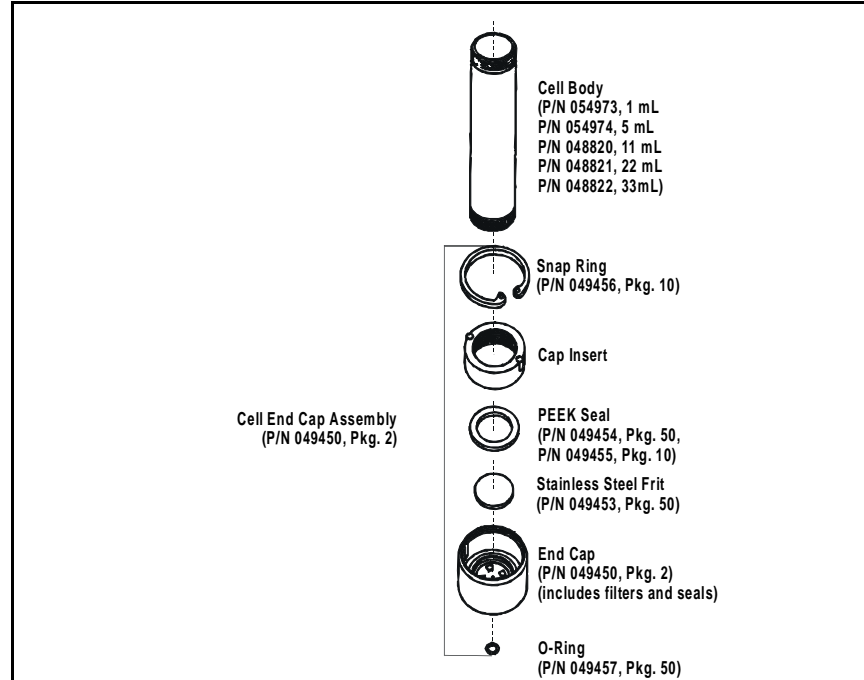

Figure 5-1. Cell Assembly

4. Remove the stainless steel frit from the bottom of the end cap. Clean the frit by sonicating in solvent, or replace it.
5. Place the cleaned (or new) stainless steel frit into the bottom of the end cap. Press a new PEEK seal into the bottom of the cap insert. Align the pins in the cap insert with the grooves in the end cap and then place the insert, with the PEEK seal facing down, into the end cap.
6. Set the cap assembly upright on the workbench. To install the snap ring, insert the snap ring tool into the holes on the ring and squeeze the tool handles to bring the ends of the ring together. Insert the ring into the cap. Use your fingers to push the ring under the lip of the end cap. After making sure the entire ring is under the lip, release the tension on the tool and remove the tool from the ring.
7. Screw the cap back onto the cell body and hand-tighten.

5.2 Replacing Tubing and Fittings

The ASE 200 is plumbed with the following tubing and fittings:

P/N	Description/Used For
048811	AutoSeal tip assembly
049311	Tubing assembly; AutoSeal solvent inlet and outlet lines
049610	7-in long, 0.5-mm (0.020-in) ID stainless steel tubing
049612	8-in long, 0.5-mm (0.020-in) ID stainless steel tubing

Use a 3/16-inch open-end wrench (P/N 049452) to tighten the solvent inlet and outlet line fittings. **Do not overtighten!**

Use a 1/4-inch open-end wrench (P/N 049452) to tighten other stainless steel fittings.

Dionex ferrule fittings (P/N 043276) and 10-32 fitting bolts (P/N 043275) are used for PEEK tubing connections. For tightening requirements, see *Installation of Dionex Ferrule Fittings* (Document No. 034213).

5.3 Cleaning and/or Replacing Pump Check Valves

A dirty or worn check valve causes an erratic pump flow rate, which prevents the pump from delivering the expected volume of solvent.

Removing the Pump

1. Turn off the power switch.
2. Open the left-side panel door. Disconnect the red and blue tubing from the two black elbow press fittings on top of the pump.
3. Use a 1/4-inch wrench to disconnect the stainless steel fitting from the outlet check valve (see Figure 5-2).
4. Disconnect the Teflon fitting from the inlet check valve.
5. Disconnect the gray cable from the pump to the J8 connector on the valve driver card.
6. Loosen (but do not remove) the six Phillips screws that secure the component panel to the door.
7. Tip the panel upright. On the back of the panel, loosen the two screws that attach the pump to the panel. Slide the pump up and remove it from the panel.

Removing the Inlet Check Valve

1. Use a 1/2-inch wrench to loosen the check valve housing. Remove the housing, and then remove the check valve cartridge from the housing.

Removing the Outlet Check Valve

1. Turn the pump over, so that the outlet check valve is facing down.
2. Use a 1/2-inch wrench to loosen the check valve housing. Remove the housing, and then remove the check valve cartridge from the housing.

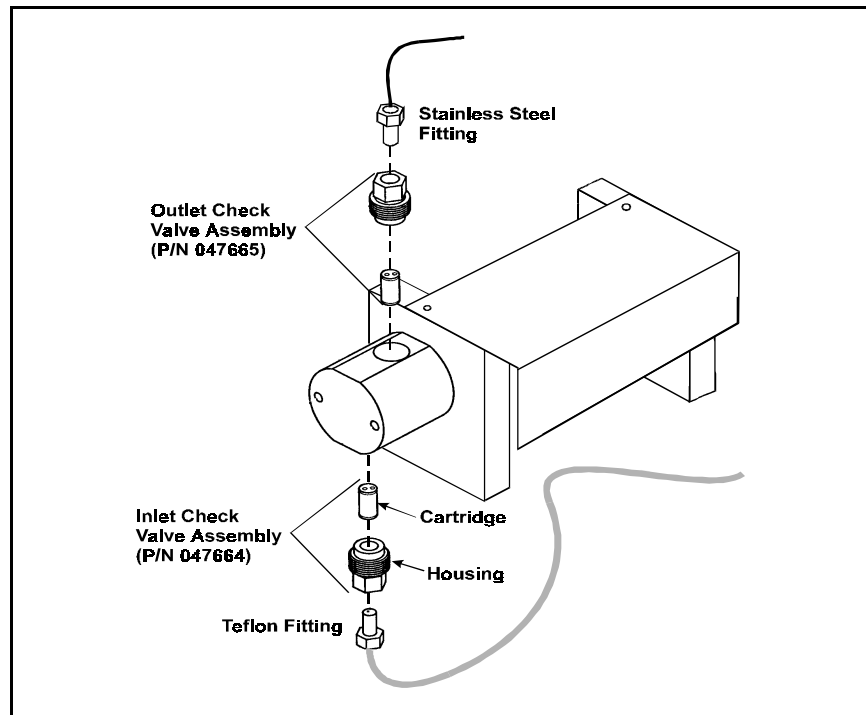

Figure 5-2. Pump Check Valves

Cleaning the Check Valves

1. Place the check valve housings and cartridges in a beaker with methanol. Sonicate or agitate for several minutes.
2. Rinse each check valve housing and cartridge thoroughly with filtered, deionized water.

Replacing the Inlet Check Valve

1. The inlet check valve assembly housing has a 1/4-28 port (the larger port). Replace the cartridge in the inlet check valve housing so that the double-hole end of the cartridge is visible. Liquid flows through the check valve in the large single hole and out the small double holes.

2. Reinstall the check valve. Tighten just enough to seat (25 in-lb torque). Tighten a little more only if it leaks.



Overtightening may damage the pump head and the check valve housing and crush the check valve seats.

Replacing the Outlet Check Valve

1. The outlet check valve assembly housing has a 10-32 port (the smaller port). Replace the cartridge in the outlet check valve housing so that the single-hole end of the cartridge is visible. Liquid flows through the check valve in the large single hole and out the small double holes.
2. With the pump still inverted, reinstall the check valve. Tighten just enough to seat (25 in-lb torque). Tighten a little more only if it leaks.



Overtightening may damage the pump head and the check valve housing and crush the check valve seats.

Reinstalling the Pump

1. Reinstall the pump on the component panel.
2. Reattach the component panel to the left-side panel door.
3. Reconnect the two air lines to the press fittings on the top of the pump.
4. Reconnect the solvent lines to the inlet and outlet check valve housings.
5. Reconnect the electrical connector to J6 on the valve driver card.

Completing the Procedure

1. Turn on the power switch.
2. Rinse the system (see Section B.2.9). If the system will not rinse and all other possible causes of the problem have been eliminated, replace the check valve cartridges (P/N 047755).

5.4 Replacing Piston Seals

Leaking from the pump head indicates that the piston seal and piston rinse seal should be replaced.

Removing the Pump

1. Turn off the power switch.
2. Open the left-side panel door. Disconnect the red and blue tubing from the two black elbow press fittings on top of the pump.
3. Use a 1/4-inch wrench to disconnect the stainless steel fitting from the outlet check valve (see Figure 5-2).
4. Disconnect the Teflon fitting from the inlet check.
5. Disconnect the gray cable from the pump to the J8 connector on the valve driver card.
6. Loosen (but do not remove) the six Phillips screws that secure the component panel to the door.
7. Tip the panel upright. On the back of the panel, loosen the two screws that attach the pump to the panel. Slide the pump up and remove it from the panel.

Replacing the Piston Seal

1. Using a 7 mm nut driver or wrench, loosen and remove the two nuts securing the pump head to the body.
2. Slide the pump head off the bolts.
3. Locate the piston seal (orange with a white internal ring) behind the tan piston guide in the pump head.
4. Insert the new piston seal (P/N 047583), with the white ring face down, into the pump head.
5. Reinstall the pump head into the pump body.

Replacing the Piston Rinse Seal

1. Remove the black cover from the side of the pump.
2. Remove the small electronics card from the side of the pump.
3. Using a 7 mm nut driver or wrench, loosen and remove the nuts from the ends of the bolts that secure the end plates to the pump body.
4. Remove the left end plate from the pump cylinder, exposing the piston.
5. Remove the piston rinse seal from the left end plate. The rinse seal is orange, as is the piston seal, but does not contain a white ring.
6. Insert the new piston rinse seal (P/N 048722), with the closed end facing down, into the end plate. Gently press the seal into place with a cotton-tipped swab (or other tool with a soft tip).
7. Verify that the piston rinse seal was properly installed by sliding the piston backwards through the hole. If the seal sticks to the piston and comes out of the left end plate, it was not installed firmly enough. Gently press the seal into place.
8. Secure the pump cylinder to the end plates and tighten the bolts.

9. Reattach the electronics card to the side of the pump and replace the black cover.

Reinstalling the Pump

1. Reinstall the pump on the component panel.
2. Reattach the component panel to the left-side panel door.
3. Reconnect the two air lines to the press fittings on the top of the pump.
4. Reconnect the solvent lines to the inlet and outlet check valve housings.
5. Reconnect the electrical connector to J6 on the valve driver card.
6. Turn on the power switch.

5.5 Replacing the Pressure Relief Valve

Leaking into the waste vial when the pressure relief valve is closed indicates a dirty or worn valve.

1. Turn off the power switch.
2. Open the left-side panel door.
3. The relief valve (P/N 048889) is installed directly above the pump on the component panel. Disconnect the green tubing from the elbow press fitting on the valve.
4. Disconnect the stainless steel line from the left side of the valve. This tubing connects to the transducer.
5. Disconnect the stainless steel line from the right side of the valve. This tubing connects to the upper AutoSeal arm.
6. Disconnect the green PEEK waste line.
7. Loosen the two screws on the bracket that secures the valve to the panel. Slip the screws through the keyholes on the bracket and remove the valve.
8. Install the new valve on the bracket and tighten the screws. Reconnect all of the lines.

5.6 Replacing the Static Valve

Leaking from the source needle into the collection vial when the static valve is closed indicates a dirty or worn valve.

1. Turn off the power switch.
2. Open the left-side panel door.
3. The static valve (P/N 048778) is installed on the rear of the needle mechanism. Disconnect the two stainless steel lines from the valve.
4. Disconnect the orange tubing from the elbow press fitting on the valve.
5. Loosen the two screws on the bracket that secures the valve to the needle mechanism. Slip the screws through the keyholes on the bracket and remove the valve.
6. Install the new valve on the bracket and tighten the screws. Reconnect all of the lines.

5.7 Replacing Needles

5.7.1 Vent Needle

1. Turn off the power switch.
2. Open the left-side panel door and locate the needle assembly on the inside wall of the ASE 200.
3. Remove the vial needle cover. To do this, use a Phillips screwdriver to loosen the two screws located on the back of the needle mechanism (see Figure 5-3). Pull the needle mechanism to the left toward the back of the instrument. Lift the cover up and off. Push the mechanism back toward the vial tray.

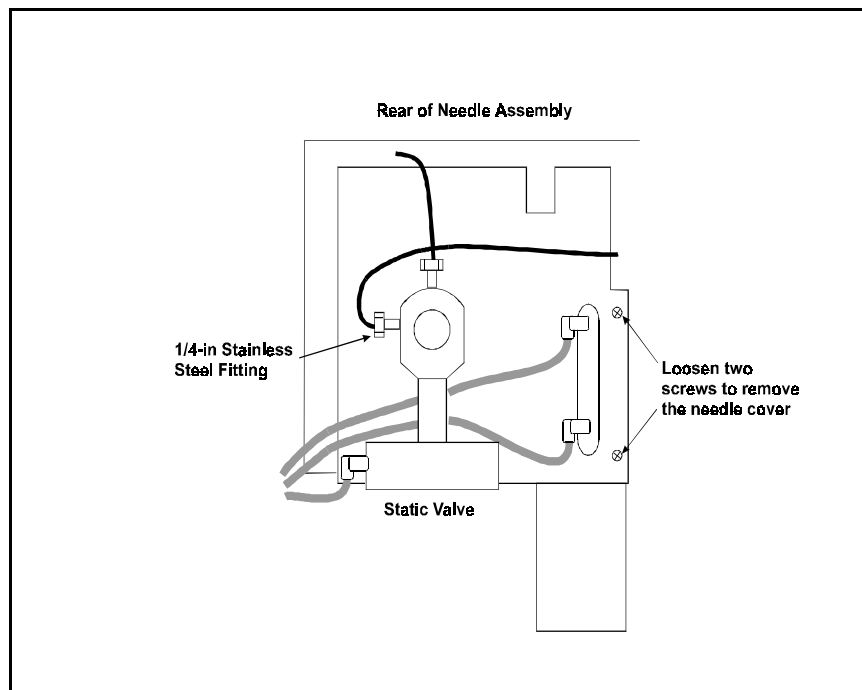

Figure 5-3. Rear View of Needle Mechanism

4. Grasp the center handle of the vial tray and lift straight up to clear the tray from its support base. Remove the tray from the instrument.
5. The vent needle is the slightly shorter needle with clear tubing attached (see Figure 5-4). Pull the clear tubing from the needle.
6. Use a Phillips screwdriver to loosen the screw on the needle block (see Figure 5-4). Pull down to remove the needle.
7. Orient the new vent needle (P/N 049255) with its opening toward the rear of the needle block. Insert the needle into the bottom of the needle block and tighten the screw.

NOTE

The needle is slightly loose in the needle block, even when the screw is tightened.

8. Push the clear tubing onto the new vent needle.
9. Replace the vial tray and the vial needle cover. Close the left-side panel door.

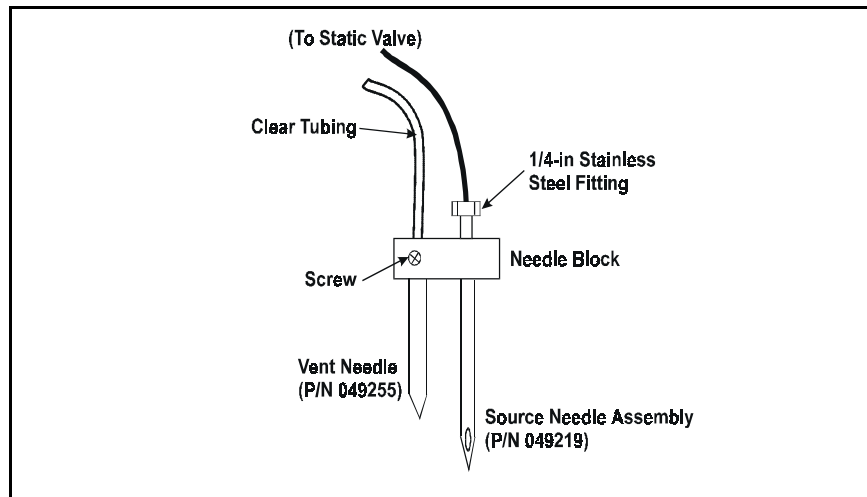

Figure 5-4. Vent and Source Needles

5.7.2 Source Needle

1. Turn off the power switch.
2. Open the left-side panel door and locate the needle assembly on the inside wall of the ASE 200.
3. Remove the vial needle cover. To do this, use a Phillips screwdriver to loosen the two screws located on the back of the needle assembly (see Figure 5-3). Pull the needle assembly to the left, toward the back of the instrument. Lift the cover up and off. Push the assembly back toward the vial tray.
4. Use a 1/4-inch open-end wrench to disconnect the stainless steel fitting on the left side of the static valve.
5. From the right side of the ASE 200, disconnect the 1/4-inch stainless steel fitting from the needle block (see Figure 5-4).
6. Pull the needle assembly to the left, toward the back of the instrument, and remove the source needle.
7. Orient the new source needle assembly (P/N 049219) with the opening toward the front of the needle block. Insert the needle into the needle block from the top.
8. Replace the stainless steel tubing and fittings on the static valve and the needle block.
9. Replace the vial needle cover and close the left-side door.

5.8 Changing the Main Power Fuses

1. Turn off the main power.



HIGH VOLTAGE—Disconnect the main power cord from its source and also from the rear panel of the ASE 200.

2. The fuse holder is part of the main power receptacle on the rear panel. A recessed lock is located on each side of the fuse holder (see Figure 5-5). Using a small screwdriver or your fingernails, push each lock toward the center to release it. The fuse holder pops out approximately 0.16 cm ($\frac{1}{16}$ inch) when the locks release. When both locks are released, pull the fuse holder straight out of its compartment.
3. The holder contains two fuses. Replace these with new IEC127 fast-blow fuses rated 3.15 amps (P/N 954745). Dionex recommends replacing both fuses even though only one is open; the other fuse has been stressed and could fail even under normal operation.

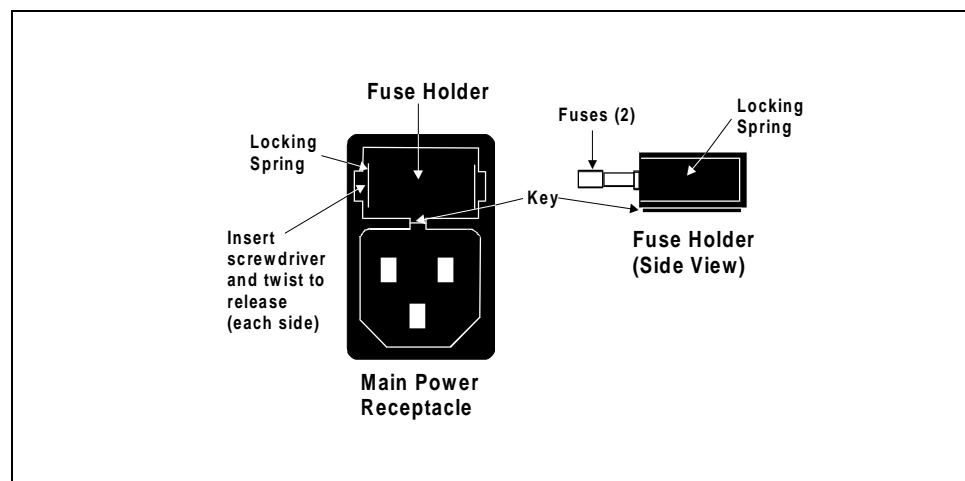

Figure 5-5. Main Power Fuse Holder

4. Reinsert the fuse holder into its compartment. The fuse holder is keyed to fit only in its proper orientation. Apply sufficient pressure evenly against the holder to engage the two locks. The holder is flush against the panel when both locks are engaged.
5. Reconnect the main power cord and turn on the power.

5.9 Calibrating the Hydrocarbon Sensor

When the hydrocarbon sensor reading is low and the sensor needs to be calibrated, an on-screen error message is displayed.

1. Open the **HYDROCARBON CALIBRATION** screen (option 4 on the **DIAGNOSTIC MENU**).
2. Open the front panel door and swing it toward the cell carousel.
3. Remove the rear cover of the ASE 200.

The motor driver card (labeled Tray MTR/AS) is on the rear panel, above the fan. The hydrocarbon sensor is plugged into position J14 on the card. The R1 potentiometer (pot) is located immediately to the left of the sensor.



Figure 5-6. Accessing the Hydrocarbon Sensor

4. Stand behind the ASE 200 in a location from which you can clearly see the **HYDROCARBON CALIBRATION** screen (see Figure 5-6).
5. Turning the R1 pot clockwise decreases the value; turning it counterclockwise increases the value. Using a small flathead screwdriver or a trimmer adjuster (P/N 035617), begin adjusting the R1 pot (see Figure 5-7). When the **ACTUAL SENSOR READING** is set to 4000, press **Enter** to calibrate the **UPPER VAPOR THRESHOLD**.

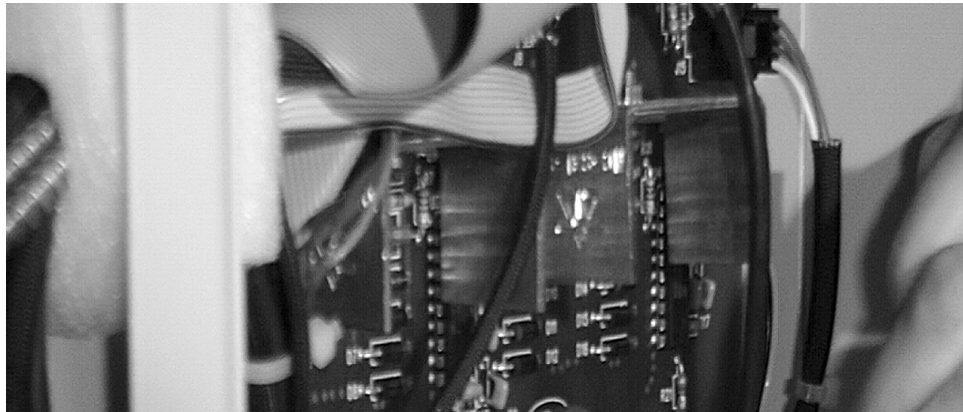

Figure 5-7. Adjusting the R1 Potentiometer

6. Reinstall the rear cover and wait for the sensor to equilibrate. After equilibration, the **UPPER VAPOR THRESHOLD** reading should be 9500 ± 2000 . If it is not, carefully insert the screwdriver or trimmer adjuster tool through the hole on the rear cover and adjust the pot again.

NOTE

Failure to replace the rear cover invalidates the sensor test in the next step.

7. Hold an open solvent vial in the service compartment, near the rear panel, and verify that the **ACTUAL SENSOR READING** rises. Next, remove the solvent vial and verify that the **ACTUAL SENSOR READING** drops.
 - If the readings rise and fall correctly, the sensor is operating correctly. Resume routine operation.
 - If the readings do not rise and fall correctly, the sensor is defective and must be replaced. Refer to Section 5.10 for instructions.

5.10 Replacing the Hydrocarbon Sensor

1. Turn off the main power.
2. Remove the rear cover of the ASE 200.
3. The motor driver card (labeled Tray MTR/AS) is on the rear panel, above the fan. Locate the hydrocarbon sensor in position J14 of the card. Unplug the sensor by pulling it straight away from the board.

NOTE

Dionex recommends wearing latex gloves when handling the new hydrocarbon sensor.

4. The new sensor (P/N 938918) has only four prongs, although the sensor socket has six holes. Plug the sensor into the four holes indicated in Figure 5-8.
5. Replace the rear cover.
6. Turn on the main power.
7. Dionex recommends burning in the sensor overnight. If this is not possible, wait at least 2 hours for the signal to stabilize before resuming operation.

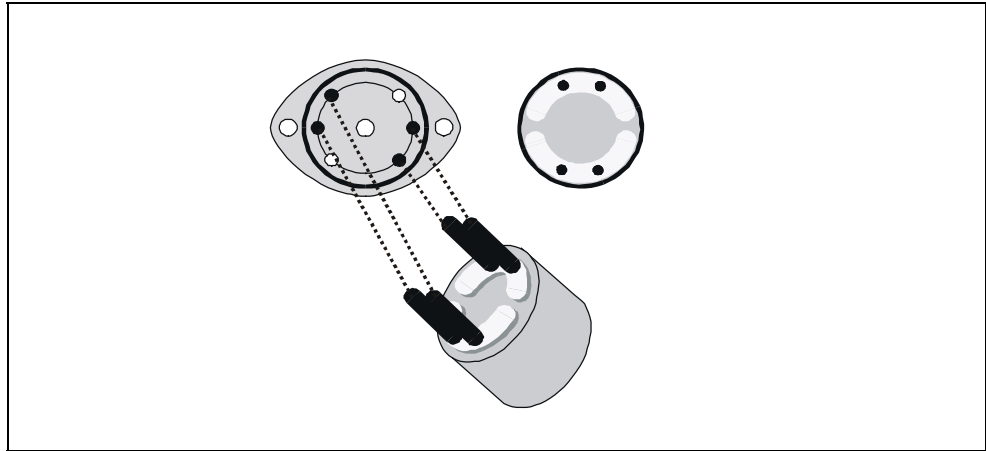

Figure 5-8. Orienting the New Hydrocarbon Sensor

A • Specifications

A.1 Electrical

Main Power Requirements	90 to 260 Vac, 50/60 Hz; less than 5 amps at 120 Vac. The ASE 200 main power supply is auto-sensing and requires no voltage adjustment.
Oven Power Requirements	Switch for selecting the heater voltage range: 90 to 130 Vac, or 220 to 260 Vac
Fuse Requirements	Two IEC127 fast-blow fuses rated 3.15 amps (P/N 954745)

A.2 Environmental

Operating Temperature	10 to 40 °C (50 to 104 °F)
Operating Humidity	5 to 95% relative humidity, noncondensing
Decibel Level	64 db (at “A WEIGHING” setting)

A.3 Physical

Dimensions	59.4 cm high x 58.8 cm wide x 60.4 cm deep (23.4 in x 23.1 in x 23.8 in)
Weight	71.6 kg (156 lb)

A.4 Pneumatic

Laboratory Air	0.41 to 1.38 MPa (60 to 200 psi)
Nitrogen	0.97 to 1.38 MPa (140 to 200 psi)

A.5 Display and Keypad

- Display** Liquid crystal with adjustable backlighting and contrast
- Keypad** 26-button keypad for entering commands and programming methods and schedules

A.6 Extraction Cells and Tray

- Extraction Cells** Stainless steel cell and caps with PEEK seals and stainless steel frits. Five cell capacities available.

Cell Capacity	Internal Cell Diameter
1 mL	5.8 mm (0.23 in)
5 mL	12.94 mm (0.52 in)
11 mL	19.1 mm (0.76 in)
22 mL	19.1 mm (0.76 in)
33 mL	19.1 mm (0.76 in)

- Cell Tray** 24 sample cell positions and four rinse positions. Tray accommodates any combination of cell sizes.

A.7 Collection Vials and Trays

- Collection Vials** Three sizes: 40 mL, 40 mL graduated, and 60 mL. Vial septa are Teflon-coated on the solvent side.
- Vial Trays** Removable tray accommodates 40 mL and 60 mL vials. Tray inserts adapt tray for standard 40 mL vials; vial spacers adapt tray for 40 mL graduated vials. Twenty-six collection vial positions and four rinse positions.

A.8 Interior Components

- Oven** Heats to 200 °C. Accommodates one cell at a time in a vertical position. Shuts off automatically after four hours of system inactivity.
- Pump** Operating pressure from 3.45 MPa to 20.7 MPa (500 psi to 3000 psi)

Valves	High pressure valves: purge, pressure relief, and static
Vial Sensors	Sensors for detecting vial present, vial containing approximately 1 mL, and full vial
Leak Sensors	Hydrocarbon vapor and liquid level

B • Installation

B.1 Facility Requirements

Provide the following installation site facilities for the ASE 200:

- A sturdy table or workbench with enough free space behind the ASE 200 for connections and ventilation.



Use caution when lifting the ASE 200. Two or more persons should lift the module, which weighs 71.6 kg (156 lb). Lift only from the bottom or side surfaces; lifting with the panel doors will damage the door hinges.

- A source of laboratory compressed air, regulated to between 0.41 and 1.38 MPa (60 and 200 psi); 0.68 MPa (100 psi) is recommended. If compressed air is unavailable, substitute nitrogen (see Section B.2.1).



To avoid contamination and possible deterioration of the pump and air valve seals, make sure laboratory compressed air is oil-free, dry, and filtered, and maintained within the pressure limits specified above.

- A source of 99.9% pure nitrogen gas, regulated to between 0.97 and 1.38 MPa (140 and 200 psi); 1.03 MPa (150 psi) is recommended. UHP (ultra-high purity) gas may be required for applications using a very clean baseline electron capture detector (ECD).
- A power source of 90 to 260 Vac; 50/60 Hz. For operation of the oven, set a switch to select either the low voltage range (90 to 130 Vac) or high voltage range (220 to 260 Vac) (see page B-6).
- A printer with an RS-232 serial interface (optional).

B.2 Installation Instructions

The ASE 200 Ship Kit (P/N 049009) contains all of the items needed to install the instrument.

B.2.1 Air/Nitrogen Connections

NOTE

This section describes two installation procedures. The first procedure explains how to connect compressed air and nitrogen gas sources to the ASE 200. The second procedure explains how to configure the system when compressed air is not available.

Compressed Air and Nitrogen Connections

NOTE

The air and nitrogen connections are press fittings. To connect a press fitting, firmly push the tubing into the fitting until it is seated. To disconnect a press fitting, use your fingers (or a small open-end wrench) to press the ring on the fitting in, while pulling the tubing out.

1. Connect the 6-mm (0.25-in) elbow fitting (P/N 214738) to the regulator on the compressed air source.
2. Push one end of the yellow 6-mm (0.25-in) OD tubing (P/N 214739) into the elbow fitting and connect the inlet filter assembly (P/N 049492) to the other end of the tubing. Check that the arrow on the filter points in the direction of the air flow (toward the ASE 200). Push the tubing on the other end of the filter assembly into the **AIR** connector on the ASE 200 rear panel (see Figure B-1).



Do not obstruct or pressurize the vent outlet.

IMPORTANT

Make sure the vent tubing runs downhill from the ASE 200 rear panel. This prevents formation of a trap, which would prevent vapors from being vented through the tubing.

3. Adjust the compressed air pressure source to between 0.69 and 1.38 MPa (100 and 200 psi); 0.69 MPa (100 psi) is recommended.
4. Connect the 4-mm (0.156-in) elbow fitting (P/N 049272) to the regulator on the nitrogen gas source. Push one end of the blue 4-mm (0.156-in) OD tubing (P/N 049296) into the elbow fitting; push the other end into the **NITROGEN** connector on the rear panel.

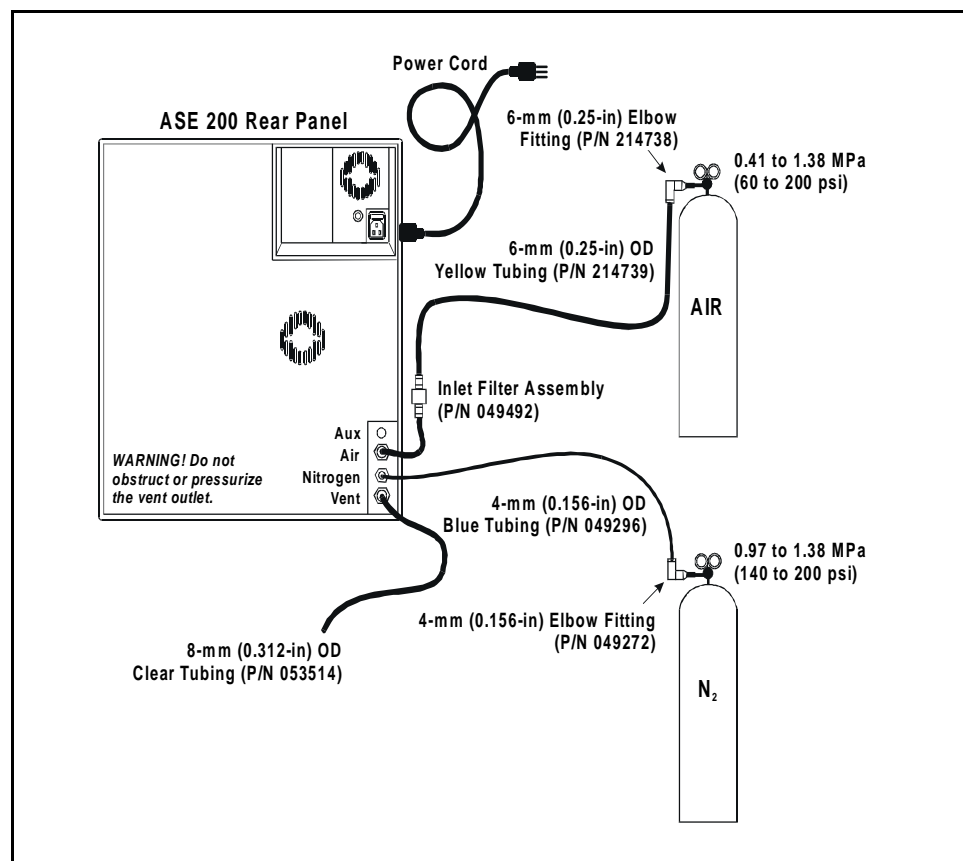

Figure B-1. Rear Panel Connections

5. Push one end of the 10-ft section of clear 8-mm (0.312-in) OD tubing (P/N 053514) into the **VENT** connector on the rear panel. Route the tubing to a vent hood, if desired.
6. Adjust the nitrogen pressure source to between 0.97 and 1.38 MPa (140 and 200 psi); 1.03 MPa (150 psi) is recommended.

Substituting Nitrogen for Compressed Air

This section describes how to connect the nitrogen gas source to the **NITROGEN** and **AIR** connectors on the ASE 200 rear panel.

NOTE

The nitrogen connections are press fittings. To connect a press fitting, firmly push the tubing into the fitting until it is seated. To disconnect a press fitting, use your fingers (or a small open-end wrench) to press the ring on the fitting in, while pulling the tubing out.

1. Connect the yellow 6-mm (0.25-in) OD tubing end of the tee assembly to the **AIR** connector on the ASE 200 rear panel (see Figure B-2).
2. Connect the blue 4-mm (0.156-in) OD tubing end of the tee assembly to the **NITROGEN** connector on the rear panel.
3. Wrap Teflon tape around the threads of the 6-mm (0.25-in) elbow fitting (P/N 214738) and then connect the fitting to the regulator on the nitrogen gas source. Push one end of the yellow 6-mm (0.25-in) OD tubing (P/N 214739) into the elbow fitting; push the other end into the fitting on the tee assembly.

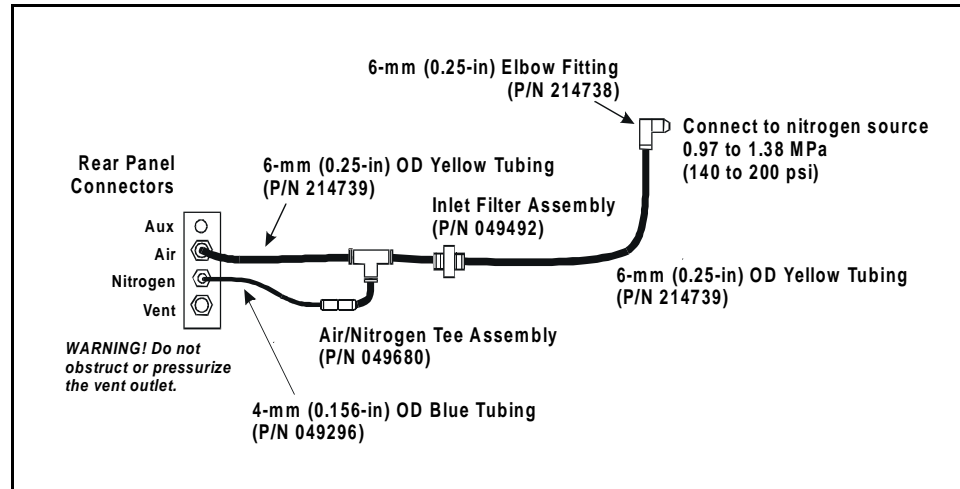

Figure B-2. Connections for Substituting Nitrogen for Air

B.2.2 Electrical Connections

1. Connect a modular power cord (IEC 320 C13) from the power receptacle on the rear panel to a grounded, single-phase power source of 90 to 260 Vac and 50/60 Hz.



SHOCK HAZARD—To avoid electrical shock, a grounded receptacle must be used. Do not operate or connect to AC power mains without an earthed ground connection.



The power cord is used as the main disconnect device. Make sure the power source outlet is located near the ASE 200 and is easily accessible.



Operation at AC input levels outside the specified operating voltage range may damage the ASE 200.

2. Check the voltage range switch beside the power receptacle (see Figure B-3); if the setting does not match the voltage from the power source, reset the switch. To do so, insert a small screwdriver into the slot and turn the switch to the 110 setting (for voltages between 90 and 130 Vac) or the 220 setting (for voltages between 220 and 260 Vac).

NOTE

The voltage range switch is required for operation of the oven only. The switch does not affect other system components. The main power supply, used for system operation, adjusts automatically to the power source.

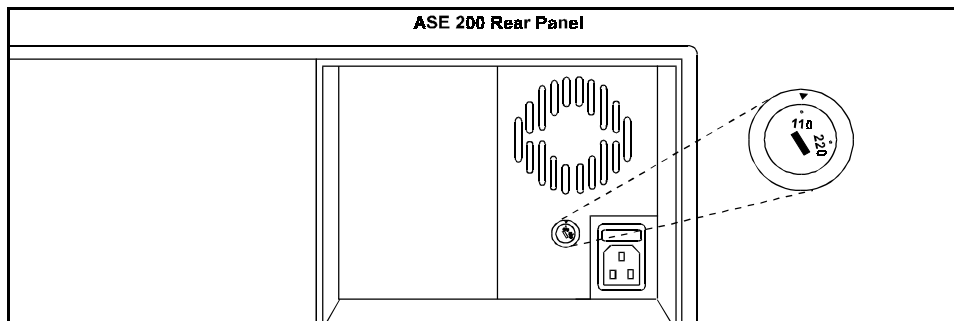

Figure B-3. Voltage Range Switch

B.2.3 DX-LAN Network Connections (Optional)

For the ASE 200 to communicate with AutoASE software, a DX-LAN interface card must be installed in the ASE 200 and a DX-LAN cable must be connected to the rear panel. The procedure below explains how to install these items.

IMPORTANT

STATIC—The ASE 200 electronics cannot be serviced by the user. The DX-LAN interface card should be installed by qualified personnel only. Be sure to observe standard anti-static procedures when installing the interface card.

IMPORTANT

To prevent damage to the ASE 200, turn off the main power before installing the DX-LAN interface card. After confirming that the LED on the CPU card is off (not green or red), unplug the power cord from the mains. Do not rely on the front panel power switch.

1. Open the ASE 200 upper front door. Remove the TTL/Relay plugs from the connectors at slot 4 (the SP card) of the electronics chassis. (The label on the inside of the front door identifies the card locations.)
2. To disconnect the 60-pin ribbon cable from the front panel, first close the tilt panel to expose the connector and its ejector latches. Remove the cable by opening the ejector latches.
3. Using a screwdriver as a lever, open the white ejector latch at the bottom of the CPU card. Remove the CPU card, cable, and Relay card as a single unit.
4. Insert the DX-LAN interface card (P/N 044195) into slot 4. Slide the card to the rear. Verify that the BNC connector is aligned with the hole at the rear and that the card is aligned with the connector. Press firmly on the card until it mates fully with the DX-LAN connector on the rear panel.

5. Reinstall the CPU/Relay card. Press firmly until the CPU card is inserted into the connector on the rear panel.
6. Reconnect the ribbon cable to the 60-pin connector on the front panel. The header and connector are key-polarized near the center. The ejector latches should be partially open to accept the cable connector.
7. If the ASE 200 is the last module in the network to be connected, install a terminator plug (P/N 921034) on the remaining port of the BNC tee connector. (The terminator plug is shipped with AutoASE.)

If the ASE 200 is not the last module, connect the cable from the next module to the BNC tee.

IMPORTANT

Terminator resistor plugs must be installed at each end of the DX-LAN. Verify that both ends of the DX-LAN have resistor plugs installed.

8. Connect the DX-LAN cable (P/N 960404) to the DX-LAN connector on the rear panel.

NOTE

A 15-meter (50-ft) DX-LAN extension cable (P/N 046016) is available from Dionex.

B.2.4 Check Pressure Readings

1. Open the lower front door and verify that the factory-set pressures on the air and gas gauges are correct (see Figure B-4 and the table below).

Gauge	Pressure
Solvent Bottle	10 ± 1
System Air	50 ± 3
Compression Oven	130 ± 5

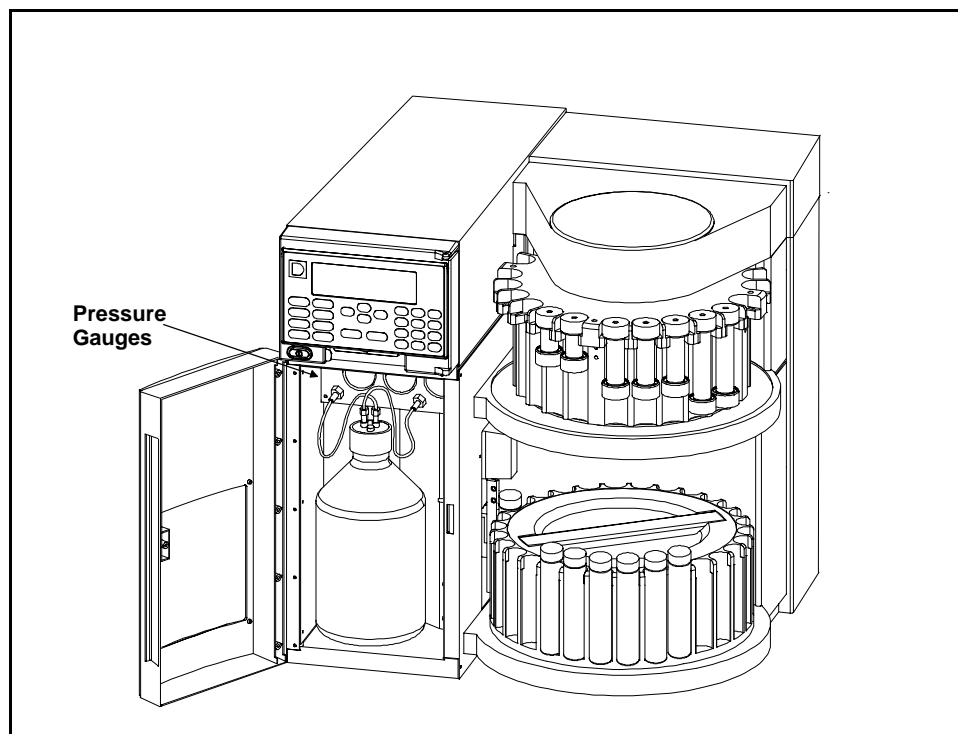

Figure B-4. Location of Pressure Gauges

2. If one or more of the pressure readings requires adjustment, open the left-side panel door to gain access to the regulators (see Figure B-5). The three regulator knobs correspond to the three gauges in the solvent reservoir compartment. To adjust a pressure, pull the appropriate regulator knob out, rotate until the corresponding pressure gauge shows the correct reading, and then push the knob back in.

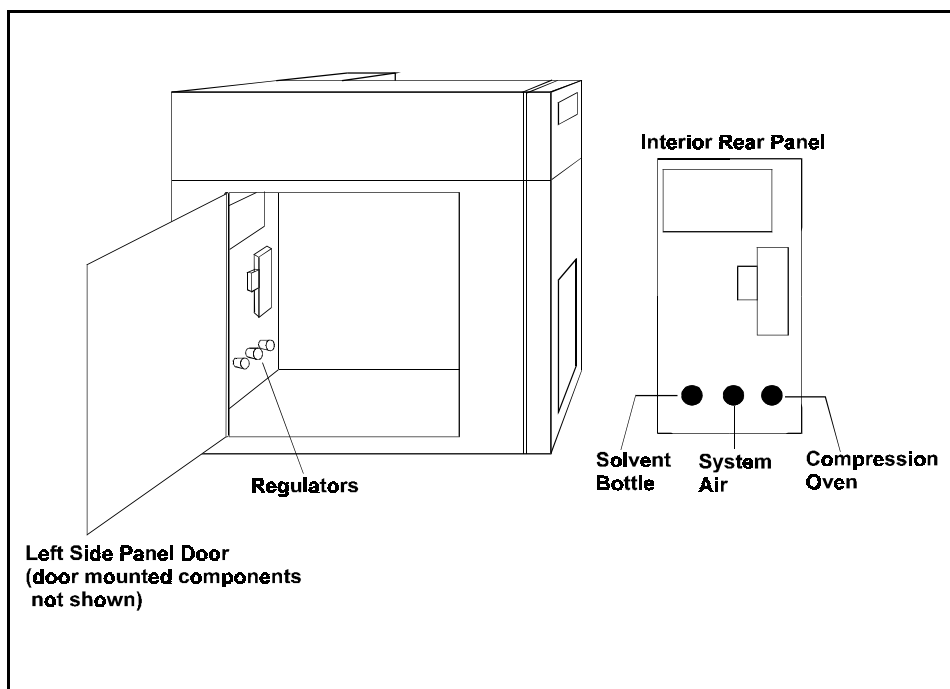

Figure B-5. Location of Regulators

B.2.5 Solvent Reservoir Compartment Connections

Solvent Reservoir Connections

NOTE

When operating with an ASE 200 Solvent Controller, disregard this section and follow the instructions in the Solvent Controller manual.

1. Fill the solvent reservoir (P/N 045901) with a prepared solvent, such as acetone. See Section 3.1.1 for information about selecting and preparing solvents.



Use only Dionex solvent reservoirs. These are glass reservoirs with a plastic, shatterproof coating. To prevent operator injury, make sure the pressure applied to the reservoirs does not exceed 0.07 MPa (10 psi).

2. Insert the outlet line extending from the underside of the reservoir cap assembly (P/N 049496) into the reservoir (see Figure B-6). Make sure that the in-line filter rests on the bottom of the reservoir; this prevents air from being drawn through the line. If necessary, gently pull on the outlet line to bring more line into the reservoir.
3. Hand-tighten the cap securely over the stopper.
4. Set the reservoir in the solvent reservoir compartment. Screw the fitting on the solvent outlet line into the connector labeled **SOLVENT** at the top of the reservoir compartment (see Figure B-6).
5. Push the fitting on the gas inlet line into the connector labeled **GAS**. (To disconnect the line, push down on the small latch at the top of the connector and pull the fitting out.)

6. When refilling the reservoir, remove the cap and stopper and remove the reservoir from the compartment. It is not necessary to disconnect the solvent and gas lines.

NOTE

Fill the reservoir only when the ASE 200 is idle. The reservoir is pressurized during rinse cycles and sample extractions.

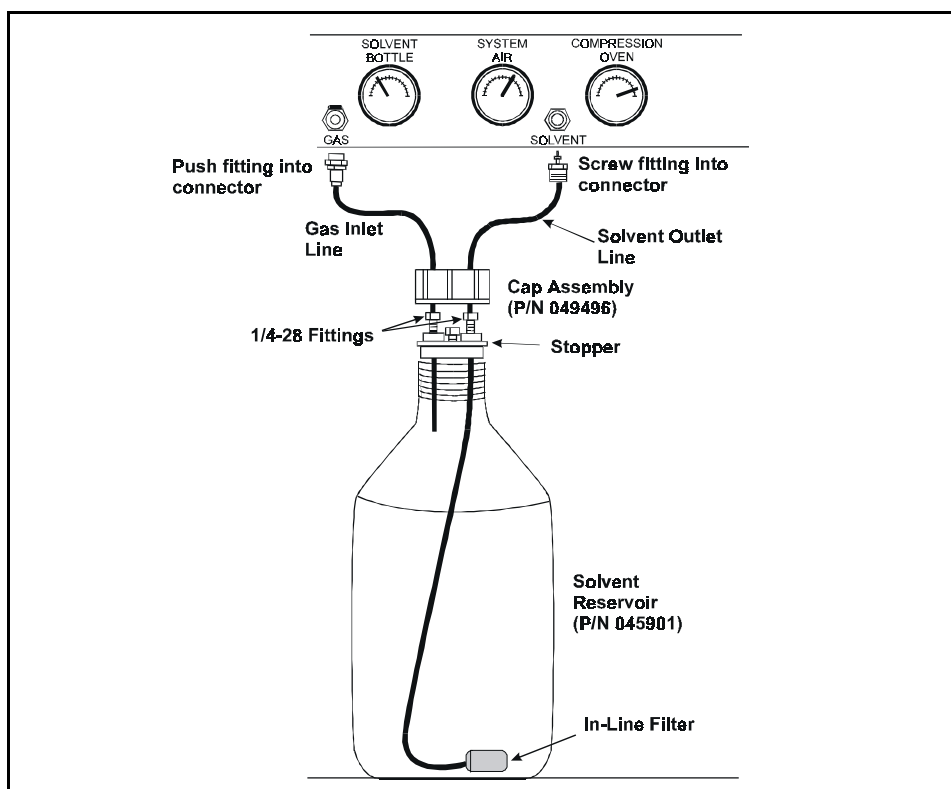

Figure B-6. Solvent Reservoir Assembly

Waste Vial Installation

7. Use a 40 mL or a 60 mL collection vial for waste collection. The waste vial installs in a holder on the right inside wall of the solvent reservoir compartment (see Figure B-7). The bottom bracket of the holder can be installed in one of two locations, depending on the size of the waste vial (see Figure B-7). The upper location is for 40 mL vials and the lower location is for 60 mL vials. If necessary, remove the two mounting screws (using a 2.5-mm Allen wrench or a Phillips head screwdriver) and reattach the bracket in the correct location.

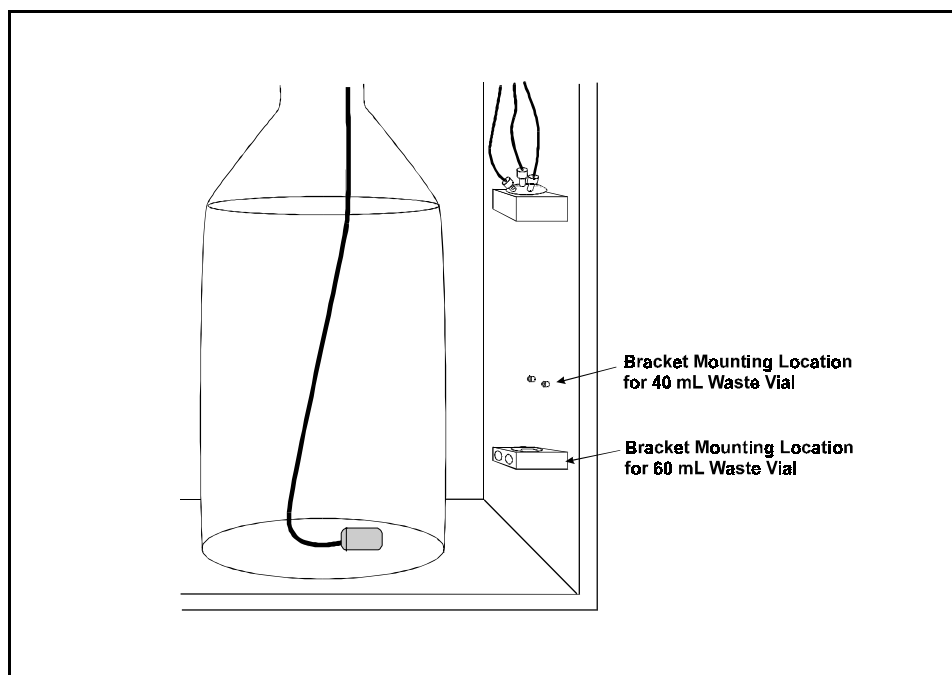

Figure B-7. Waste Bracket Mounting Locations

8. To install the vial, tilt it at about a 15° angle and align the lip of the vial with the opening under the top bracket of the holder (see Figure B-8, view A).
9. Push the lip of the vial up into the top bracket and straighten the vial until it is vertical and rests on the bottom bracket (see Figure B-8, view B). To remove the vial, push it up. Then tilt it out and pull it down and away from the bracket.

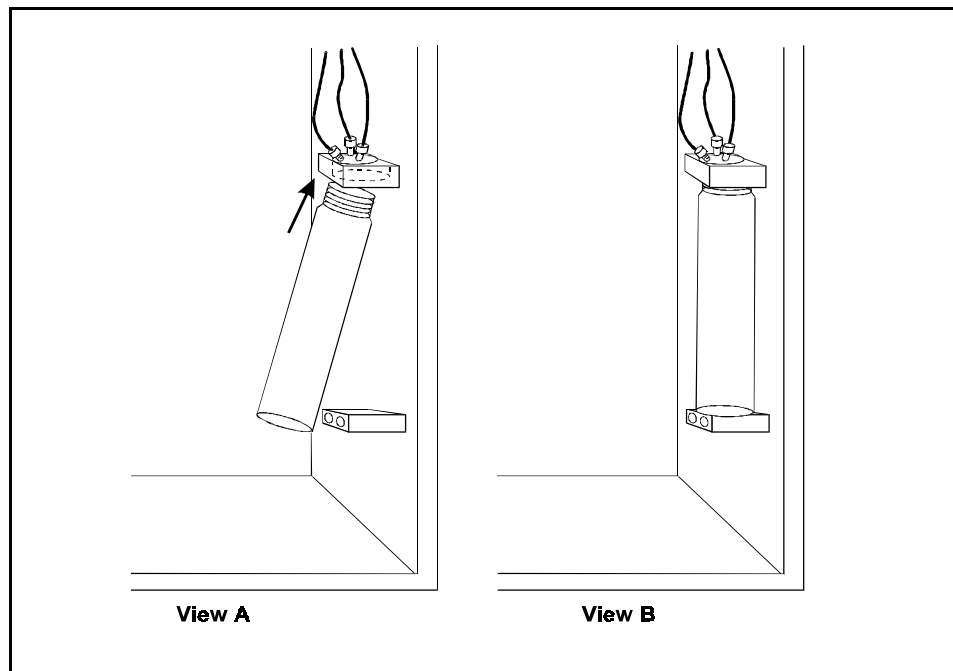

Figure B-8. Waste Vial Installation

B.2.6 Vial Tray Installation

1. Grasp the vial tray from the top handle and center the tray over the support base until it slips into place on the support platter.
2. (Optional) Turn the tray manually (in either direction) until you hear a click; this indicates that the tray is locked into the correct position.

B.2.7 Cell and Rinse Tube Inspection

White O-rings are installed in the exterior ends of each cell cap, as well as in the ends of the rinse tubes (see Figure B-9). Before each run, inspect the caps and rinse tubes. Press any dislodged O-rings back into place and replace any missing O-rings.

Place the O-ring over the opening in the end of the cell cap or rinse tube and press it into place, using the tool (P/N 049660) provided in the Ship Kit (see Figure B-10).

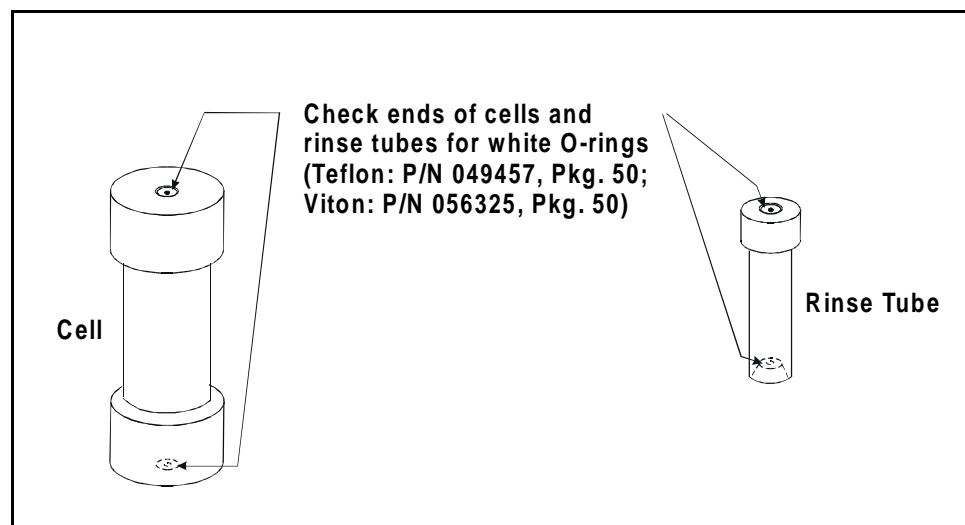

Figure B-9. O-Ring Inspection

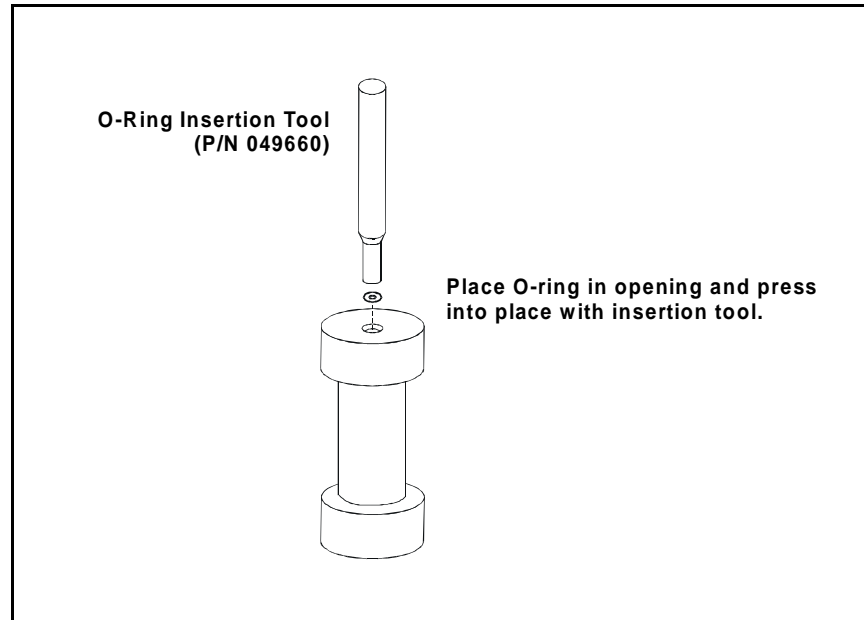

Figure B-10. O-Ring Installation

B.2.8 Power-Up

Make sure that the upper door is completely closed, and then press the power switch actuator on the lower-left corner of the door (see Figure B-11). This actuates the main power switch, located behind the door (see Figure B-15). The switch actuator works only when the door is closed. When the upper door is open, press the main power switch to turn the ASE 200 on and off.

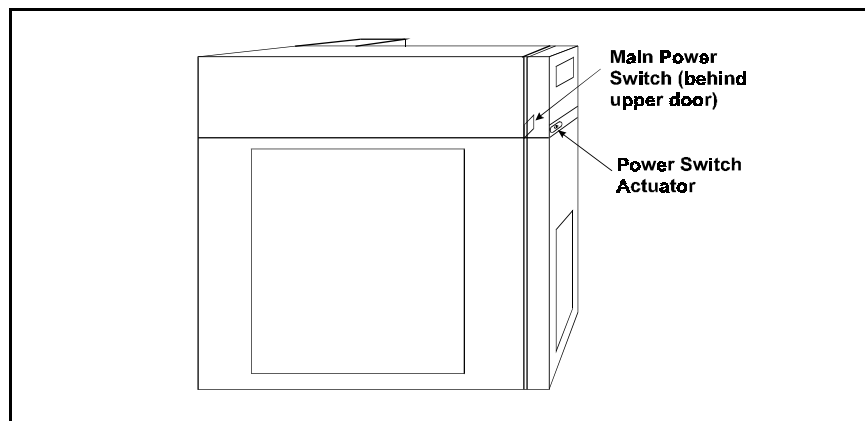

Figure B-11. Power Switch and Actuator

At power-up, the copyright and microprocessor code revision levels are displayed for a few seconds (see Figure B-12) and then the **MENU OF SCREENS** is displayed.

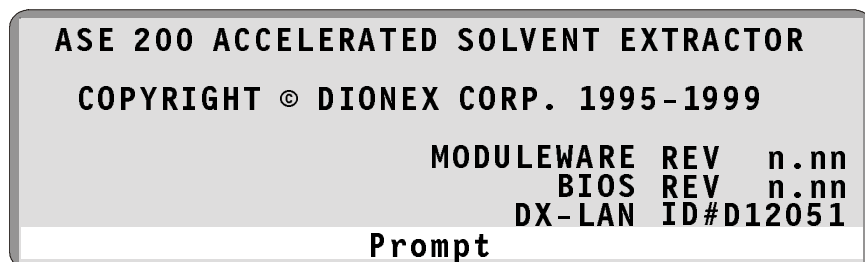

Figure B-12. Power-Up Screen

B.2.9 Rinsing/Priming the System

1. Place rinse tubes in the four rinse positions on the cell tray (between positions 1 and 24, 6 and 7, 12 and 13, 18 and 19).
2. Place collection vials in positions R1, R2, R3, and R4 in the vial tray. To adapt the vial tray positions for regular 40 mL vials, install removable inserts (P/N 049348) into the tray positions. To adapt the tray positions for graduated 40 mL vials, install vial spacers (P/N 055444) into the tray positions. No inserts or spacers are required for the 60 mL vials.
3. Press **Rinse** to start a manual rinse/prime cycle. During the cycle, the cell tray rotates to the nearest rinse tube, the vial tray rotates to a rinse position, and approximately 4 mL of solvent is pumped through the system.



To avoid personal injury, exercise caution when the tray is in motion.

4. Press **Rinse** again. After the second rinse, the pump and the solvent line are primed.

B.3 Module Setup

The **MODULE SETUP** screen controls several options, including the brightness of the display screen's backlight, the unit of measure used for pressure, and the date and time clock. Figure B-13 shows the factory default settings. Table B-1 describes each option.

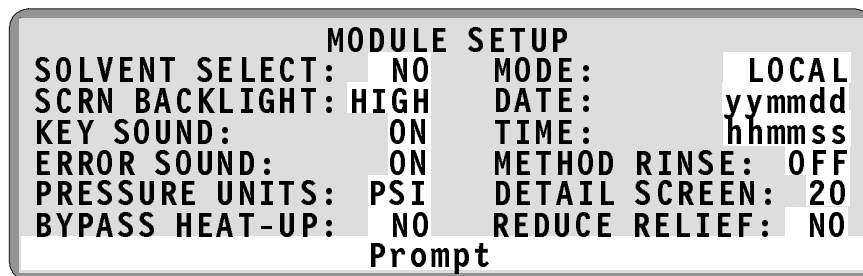

Figure B-13. Module Setup Screen

At installation, set the clock to ensure that the correct date and time are printed on reports. Also set any other options desired for the system. The selected options remain in effect until new selections are made from the screen. Turning the power off and on does not reset the options to the factory defaults.

To set options:

1. Press the **Menu** button on the front panel keypad to display the **MENU OF SCREENS** and press **5** to display the **MODULE SETUP** screen.
2. Press an arrow button to move the cursor to the desired option. For example, press ∇ to move to the **SCRN BACKLIGHT** field.
3. Press the **Select** ∇ or **Select** Δ button to select a new option or, if you are changing the **DATE**, **TIME**, or **DETAIL SCREEN** fields, enter new values by pressing numeric buttons.
4. After selecting a new option, press the **Enter** button or a cursor arrow button to save the new value.

ASE 200 Operator's Manual

Option	Description	Values
SOLVENT SELECT	Indicates whether an ASE 200 Solvent Controller is connected to the ASE 200.	NO (default) YES
SCRN BACKLIGHT	Selects the brightness of the LCD screen's backlight. The off option darkens the screen completely. When off, press any button on the keypad to turn on the light again.	LOW MEDIUM HIGH (default) OFF
KEY SOUND	When on, a low pitched beep sounds when a keypad button is pressed. Select off to disable the sound.	ON (default) OFF
ERROR SOUND	When on, a high pitched beep sounds when pressing a button results in an error message. Select off to disable the sound.	ON (default) OFF
PRESSURE UNITS	Selects the unit of measure for pressure.	(default) MPa ATM BAR
BYPASS HEAT-UP	Determines whether the initial heat-up step occurs. Selecting YES (bypassing the heat-up step) reduces the total extraction time but should be selected only if you can achieve complete recovery of analytes without heating. Note: The duration of the heat-up step depends on the method's temperature set point; see Table 3-2 for details.	NO (default) YES
MODE	Selects the mode of operation.	LOCAL (default) REMOTE
DATE	Sets the real-time clock date, which records the date and time in reports. Enter the year first, then the month, and then the day. For example, for August 23, 1999, enter 990823.	yymmdd

Table B-1. Module Setup Options

Option	Description	Values
TIME	Sets the 24-hour real-time clock. Enter the hour first, followed by minutes, and then seconds. For example, for 8:35 a.m. and 50 seconds, enter 083550. For 8:35 p.m. and 50 seconds, enter 203550.	hhmmss
METHOD RINSE	Determines whether an automatic rinse cycle is run after each sample run during method control (see Section 3.1.7 for details).	ON OFF (default)
DETAIL SCREEN	Sets the time delay in minutes for displaying the alternate large character status screen. The alternate screen automatically replaces the CURRENT STATUS screen after this set delay period (see page 3-44 for details). To disable the alternate status screen and always view the CURRENT STATUS screen, enter 99. To set a 10-second delay, enter 0.	0, 1 to 98, 99 0=10 sec 99=disable (default=20 min)
REDUCE RELIEF	Determines how long it takes to relieve system pressure after a run. Selecting YES reduces the total extraction time.	60 sec, 30 sec NO =60 sec (default); YES =30 sec

Table B-1. Module Setup Options (continued)

B.4 Printer Connections (Optional)

NOTE

The ASE 200 prints through a serial port. If it is necessary to print from a printer that is not serial-compatible, install a parallel-serial converter. Contact the nearest Dionex office for information.

1. Locate the following items in the Ship Kit:
 - Printer cable (P/N 960263) with ferrite cylinder (P/N 918019)
 - Two ferrite cores (P/N 918013)
 - 25-pin/8-pin adapter (P/N 923616)
2. Plug the 25-pin end of the adapter into the 25-pin serial connector on the printer.
3. Wind the printer cable three turns through the ferrite cylinder, if this has not been done already (see Figure B-14). Position the cylinder about 7.5 cm (3 in) from the end of the cable.

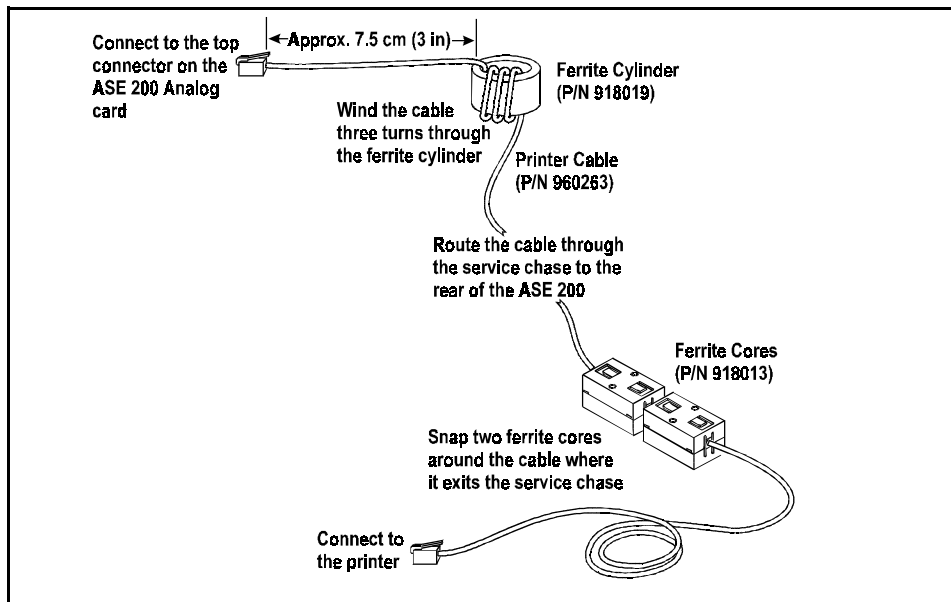
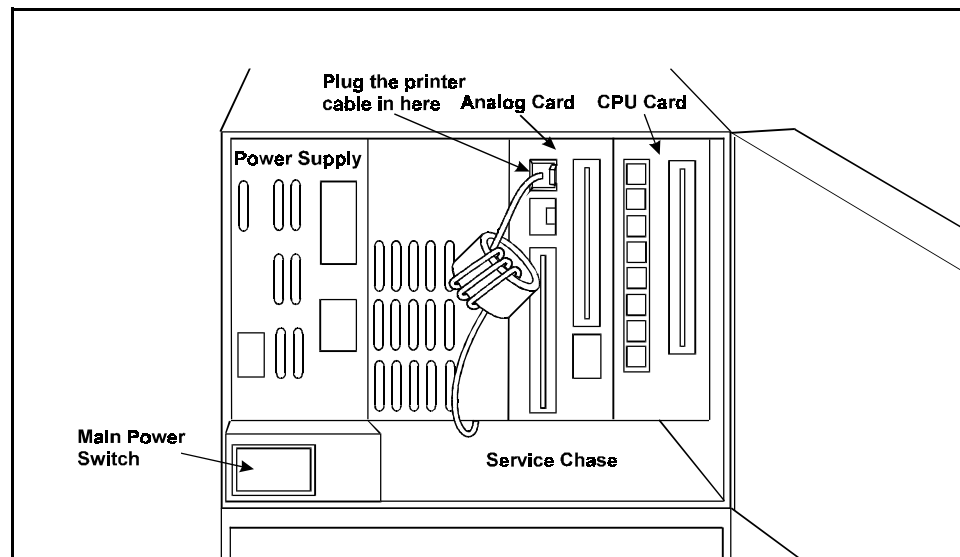

Figure B-14. Printer Cable Installation

4. Open the ASE 200 upper front door and plug the end of the cable that is closer to the ferrite cylinder into the top connector on the Analog card (see Figure B-15).
5. Route the cable through the service chase to the rear of the ASE 200 (see Figures B-15 and B-16).
6. Snap the two ferrite cores around the cable where it exits the service chase (see Figures B-14 and B-16).
7. Plug the printer cable into the 8-pin connector on the adapter that was plugged into the printer in Step 2.



*Figure B-15. Printer Cable Connection (Behind Upper Front Door)
(Other Cables Not Shown)*

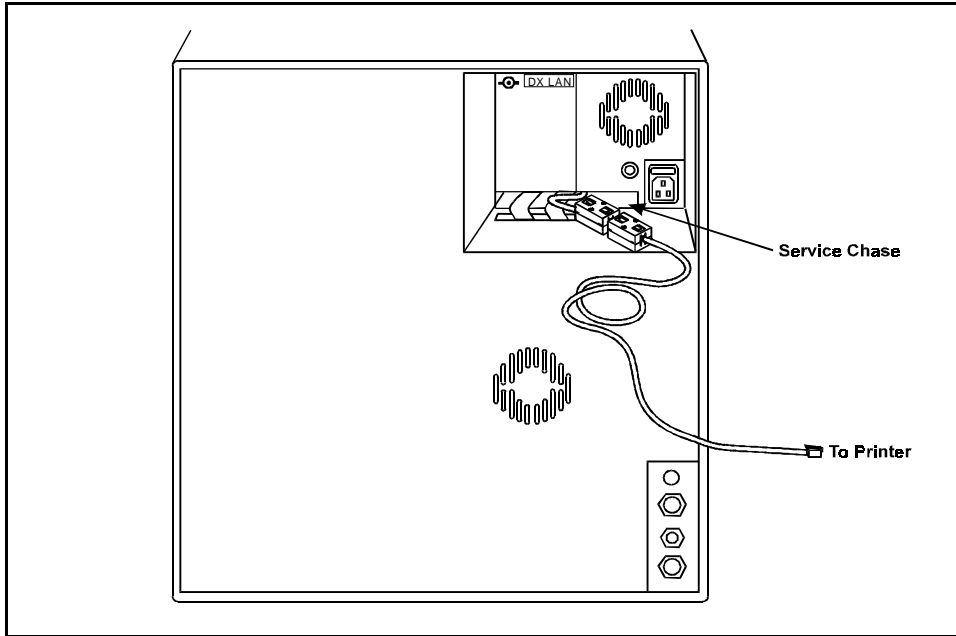

Figure B-16. Rear Panel Service Chase

C • Diagnostic Screens

This appendix describes the ASE 200 diagnostic screens. To open the **DIAGNOSTIC MENU**, select screen **7** from the **MENU OF SCREENS**.

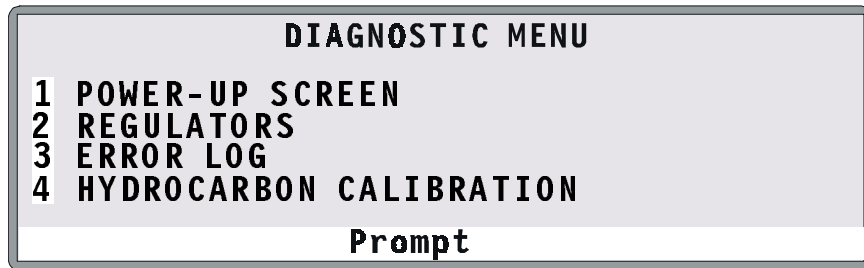

Figure C-1. Diagnostic Menu

C.1 Power-Up Screen

The **POWER-UP** screen displays the revision numbers of the ASE 200 internal control programs and the identification number of the DX-LAN interface (if connected). The screen is displayed briefly each time the ASE 200 is turned on. It is included on the **DIAGNOSTIC TEST MENU** to allow access to the information at any time.

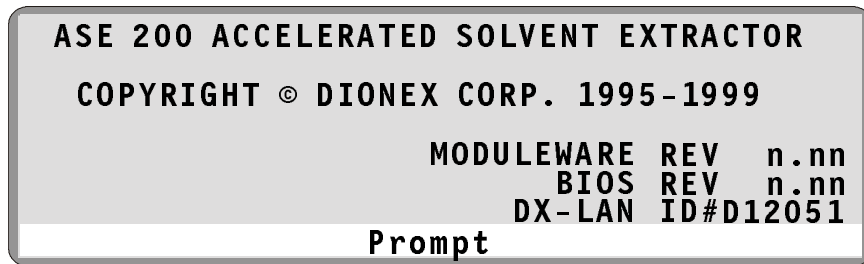

Figure C-2. Power-Up Screen

C.2 Regulators Screen

- **SYSTEM AIR PRESSURE** reports the pressure from the compressed air source. This reading should be approximately equal to the reading on the pressure gauge labeled **AIR** behind the lower door (see Figure B-4 on page B-9).
- **OVEN COMPRESSION PRESSURE** reports the nitrogen gas pressure applied to the oven compression system. When the oven is not compressed, this reading is zero. During an extraction, the oven is compressed and the reading is approximately 130 psi.
- **OVEN COMPRESSION** turns pressure to the oven compression system on and off.



Figure C-3. Regulators Screen

Figure C-4 illustrates the gas and air lines and the location of the regulators.

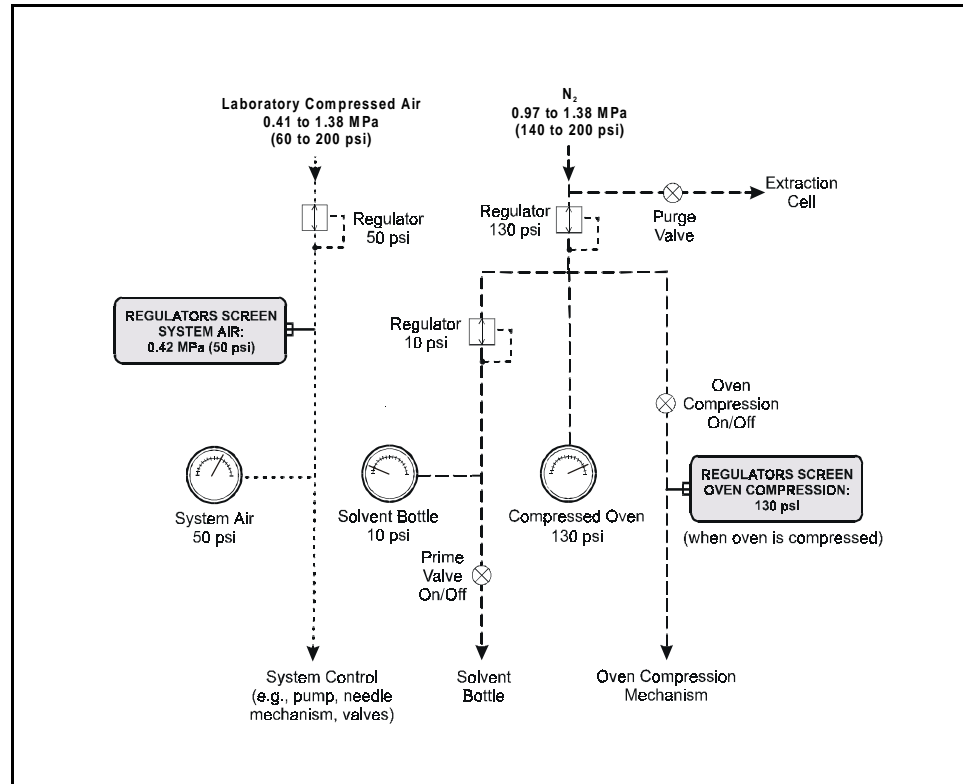

Figure C-4. Air and Gas Schematic

C.3 Error Log Screen

Records errors that occur during operation and identifies the cell and vial number in use at the time of the error.

ERROR LOG		
CELL	VIAL	ERROR MESSAGE-----
1	1	COLLECTION VIAL ERROR [319]
Prompt		

Figure C-5. Error Log Screen

When an error occurs during an extraction, the ASE 200 displays an error message on-screen and records the error on the **ERROR LOG** screen. Unless the error causes a shutdown, the ASE 200 continues on to the next cell and vial. If other errors occur during the series of runs, they are also logged. A maximum of 26 errors can be logged.

To view the list of errors after the run finishes, display the **ERROR LOG** screen (press **Menu**, and then **7**). If there are too many errors to be shown on one screen, use the arrow up and down buttons to scroll through the list. Errors remain on the **ERROR LOG** screen until another method or schedule is loaded.

See Section 4.1 for explanations of the error messages, as well as troubleshooting information.

C.4 Hydrocarbon Calibration Screen

- **ACTUAL SENSOR READING** reports the hydrocarbon level detected by the hydrocarbon sensor. This reading should remain at 2000 to 4000.
- The **UPPER VAPOR THRESHOLD** reports the solvent vapor threshold. The threshold should remain at 12000 to 15000.
- **CALIBRATE** begins the calibration procedure for the hydrocarbon sensor.

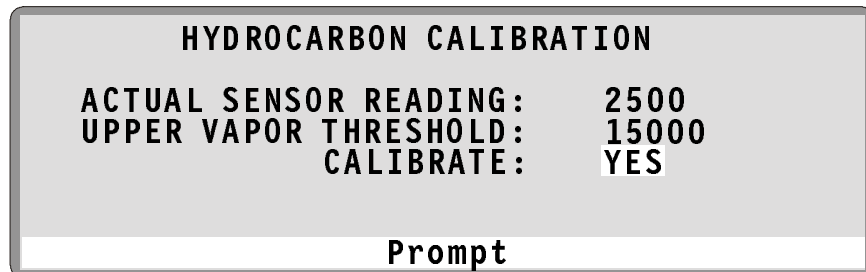

Figure C-6. Hydrocarbon Calibration Screen

For instructions on how to recalibrate the hydrocarbon sensor, refer to Section 5.9.

D • Reordering Information

P/N	Item	Quantity
048783	40 mL Clear Collection Vials	Pkg. 72
048784	60 mL Clear Collection Vials	Pkg. 72
048780	40 mL Amber Collection Vials	Pkg. 72
048781	60 mL Amber Collection Vials	Pkg. 72
049463	Lids for Collection Vials	Pkg. 72
049464	Septa for Collection Vials	Pkg. 72
055395	Teflon/Silicone Low-Bleed Septa for Collection Vials	Pkg. 72
055441	40 mL Graduated Concentration Vial Kit (includes clear glass vials, caps, and spacers)	Pkg. 6
055442	40 mL Graduated Concentration Vials	Pkg. 6
055421	1 mL Extraction Cells, Assembled	Pkg. 6
055422	5 mL Extraction Cells, Assembled	Pkg. 6
049560	11 mL Extraction Cells, Assembled	Pkg. 6
049561	22 mL Extraction Cells, Assembled	Pkg. 6
049562	33 mL Extraction Cells, Assembled	Pkg. 6
048765	11 mL Extraction Cell, Assembled	1
048764	22 mL Extraction Cell, Assembled	1
048763	33 mL Extraction Cell, Assembled	1
049450	End Caps for Extraction Cells	Pkg. 2
054973	1 mL Extraction Cell Body	1
054974	5 mL Extraction Cell Body	1
048820	11 mL Extraction Cell Body	1
048821	22 mL Extraction Cell Body	1
048822	33 mL Extraction Cell Body	1
049453	Stainless Steel Frits for Extraction Cell Caps	Pkg. 50
049454	PEEK Seals for Extraction Cell Caps	Pkg. 50
049455	PEEK Seals for Extraction Cell Caps	Pkg. 10
049456	Snap Rings for Extraction Cell Caps	Pkg. 10

ASE 200 Operator's Manual

P/N	Item	Quantity
049457	External O-Rings for Extraction Cell Caps, Teflon	Pkg. 50
056325	External O-Rings for Extraction Cell Caps, Viton	Pkg. 50
055398	Cellulose Filters for 1 mL Extraction Cell Bodies	Pkg. 100
055399	Cellulose Filters for 5 mL Extraction Cell Bodies	Pkg. 100
049458	Cellulose Filters for 11 mL, 22 mL, or 33 mL Extraction Cell Bodies	Pkg. 100
047017	Glass-Fiber Filters for 11 mL, 22 mL, or 33 mL Extraction Cell Bodies	Pkg. 100
055708	11 mL Cellulose Thimbles	Pkg. 25
055999	22 mL Cellulose Thimbles	Pkg. 25
049288	Aluminum Funnel	1
045900	1 L Glass Bottle, Plastic-Coated	1
045901	2 L Glass Bottle, Plastic-Coated	1
048670	Bottle Cap Only, Blue	1
049296	Tubing, 4-mm (0.16-in) OD Nitrogen Line	Per Ft.
053514	Tubing, 8-mm (0.31-in) OD Vent Line	Per Ft.
214739	Tubing, 6-mm (0.25-in) OD Air Line	Per Ft.
049311	Tubing Assembly, Solvent Carrier Line	1
215428	Filter for Air Inlet Line	1
049219	Source Needle	1
049255	Vent Needle	1
048771	Collection Vial Tray	1
049348	Tray Insert for 40 mL Vial	1
055444	Vial Spacer for 40 mL Graduated Concentration Vial	1

E • TTL and Relay Control

E.1 TTL and Relay Output Operation

The ASE 200 provides two TTL outputs and two relay contacts for communication with an external sample preparation device.

- To turn on a TTL or relay output, set the corresponding output field on the **TIME FUNCTION IN** screen to **1** (closed).
- To turn off a TTL or relay output, set the corresponding output field to **0** (open).

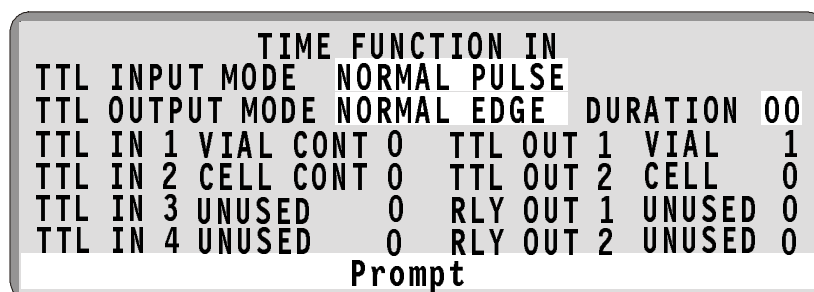

TIME FUNCTION IN							
TTL INPUT	MODE	NORMAL	PULSE				
TTL OUTPUT	MODE	NORMAL	EDGE	DURATION	00		
TTL IN 1	VIAL	CONT	0	TTL OUT 1	VIAL	1	1
TTL IN 2	CELL	CONT	0	TTL OUT 2	CELL	0	0
TTL IN 3	UNUSED		0	RLY OUT 1	UNUSED	0	0
TTL IN 4	UNUSED		0	RLY OUT 2	UNUSED	0	0

Prompt

Figure E-1. Time Function In Screen

E.2 TTL Input Operation

The ASE 200 TTL inputs can be connected to any external sample preparation device capable of providing TTL signals. The signal from the connected device can control these functions:

- **TTL input 1** controls movement of the collection vial tray.
- **TTL input 2** controls movement of the cell tray.

E.2.1 TTL Input Signal Modes

The ASE 200 TTL inputs respond to four types of signals to accommodate different types of device output signals. The default signal mode is *normal edge*. If the device connected to the ASE 200 outputs a different signal type, select a different signal mode from the **TIME FUNCTION IN** screen (see Figure E-1).

These are the four input signal modes:

- *Normal Edge*: In normal edge operation, the negative (falling) edge of a signal turns on the function and the positive (rising) edge turns off the function (see Figure E-2).
- *Inverted Edge*: The inverted edge mode works identically to the normal edge mode, except that the positive and negative edges are reversed in function.
- *Normal Pulse*: In normal pulse operation, the negative (falling) edge of the TTL signal is the active edge and the positive (rising) edge is ignored.

The minimum pulse width guaranteed to be detected is 50 ms. The maximum pulse width guaranteed to be ignored as noise or invalid is 4 milliseconds. The action of the ASE 200 is undefined for pulses less than 50 ms or greater than 4 ms.

- *Inverted Pulse*: The inverted pulse mode operates identically to the normal pulse mode, except that the positive and negative edges are reversed in function.

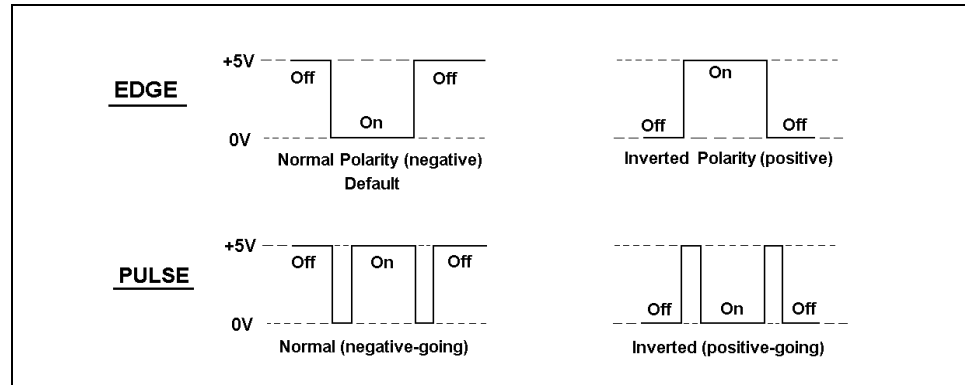

Figure E-2. TTL and Relay Input Signal Modes

ASE 200 Operator's Manual

A

- Abort button, 2-5
- Aborting a method or schedule, 2-5, 3-46
- Acetone, 3-28
- Acetonitrile, 3-28
- Acids, 3-2
- Actuator, power switch, 2-2
- Air
 - Checking the pressure, 4-14, C-2
 - Source requirements, B-1
 - Specifications, A-1
 - Substituting nitrogen for, B-20
 - Troubleshooting leaks, 4-24
- Air and gas lines schematic, C-3
- Air inlet filter, B-2
- Alt button, 2-6
- Alternate status screen, 2-13, 3-44
 - Setting the time delay, B-21
- Analytes, 2-18
- Analyzing extracts, 3-47
- Arrow buttons, 2-6
- ASE 200 Solvent Controller, 1-2, 3-28, B-11
- AutoASE software, 1-2, 3-42, 3-51
- Automatic rinse, 3-15, B-21
- AutoSeal arms, 2-2, 2-11, 2-14
 - Troubleshooting, 4-9

B

- Backlight
 - Adjusting the screen, B-20
- Bottle, 2-9
- Bottle gas gauge, B-9
- Bracket, waste vial
 - Changing the position, B-13
- Bubbles in lines, 3-14
- Buttons
 - Abort, 2-5
 - Alt, 2-6
 - Cursor arrows, 2-6
 - Delete, 2-6

- Enter, 2-6
- Help, 2-6
- Menu, 2-6
- Numeric, 2-6
- Rinse, 2-5
- Select, 2-6, 3-27, 4-2, 4-16, 4-17, 4-18
- Start, 2-5
- Trays, 2-5

C

- Cable, DX-LAN
 - Extension cable, B-8
 - Installation, B-7
- Canceling a run, 3-46
- Caps
 - see also* Cell caps
 - Vial, 2-8
- Cell caps
 - Assembly/disassembly, 5-2
 - Cleaning, 3-47
 - Replacing the frit and seal, 5-2
- Cell pressure
 - Troubleshooting, 4-11
- Cell tray, 2-2, 2-7
 - Loading, 3-10
 - Troubleshooting, 4-8
- Cells, 2-2, 2-7, 2-11
 - Cleaning, 3-47
 - Filling with sample, 3-6
 - Labeling, 3-9
 - Numbering in a schedule, 3-34
 - Sizes of, 2-7, 2-13, 3-6
 - Specifications, A-2
 - Specifying in schedules, 3-35
- Changing
 - Fuses, 5-15
- Changing solvents, 3-14
- Check valves, 5-4
- Chloroform, 3-28
- Cleaning
 - Cell cap frit, 5-3

- Cells, 3-47
 - Pump check valves, 5-4
 - Static valve, 5-11
- Collection vials, 2-2, 2-8, 2-11
 - see also* Vials
- Communication screen, 3-48
- Compressed air requirements, B-1
- Compression pressure, C-2
- Concentration of solvent, 3-28
- Contrast, adjusting the screen, 2-4
- Control modes, 2-13, 2-22, 3-10, 3-24
- Control panel, 2-2, 2-3
 - Keypad, 2-5
- Creating methods, 3-25
- Creating schedules, 3-34
- Current Status screen, 2-12
 - Setting the display time-out, B-21
- Cursor arrow buttons, 2-6
- Cycles
 - Method parameter, 3-26
 - Specifying multiple, 3-33

D

- Daily maintenance, 3-49
- Date, B-20
- Default
 - Method parameters, 3-25
 - Module setup options, B-19
 - Schedule parameters, 3-34
- Degassing solvents, 3-2
- Delete button, 2-6
- Deleting a schedule line, 2-6
- Deleting values from screen fields, 2-6
- Description
 - TTL input control, E-1
- Detail screen, B-21
- Detector interface card
 - Installation, B-7
- Developing methods, 3-40
- Diagnostic screens, C-1, C-3, C-5
- Diatomaceous earth, 3-5
- Display, 2-3
- Drying and dispersing agents, 3-4
- DX-LAN network
 - Installation, B-7

E

- Edge input signal mode, E-2
- Editing methods, 3-29
- Electrical specifications, A-1
- Electronics, 2-2
 - Troubleshooting, 4-21
- Enlarged character screen, 2-13, 3-44
- Enter button, 2-6
- Equilibrium
 - Solvent/sample, 3-41
 - Temperature, 2-16
- Error Log screen, 4-1, C-4
- Hydrocarbon sensor, 4-18
- Error messages, 4-1
- Error sounds
 - Turning on and off, B-20
- Ethanol, 3-28
- Example methods, 3-30
- Example schedules, 3-36
- Extraction cells, 2-2, 2-7, 2-11
 - see also* Cells
- Extraction process, 2-11
 - Filling the cell, 2-15
 - Flushing the cell, 2-17
 - Heating and static steps, 2-16
 - Loading the cell, 2-14
 - Purging, 2-18
 - Unloading the cell, 2-19, 2-20
- Extractions
 - Running multiple on each cell, 3-39
 - Running under method control, 3-42
 - Running under schedule control, 3-45
- Extracts
 - Analyzing, 3-40, 3-47

F

- Facility requirements, B-1
- Features, 2-1
- Filling the cell, 2-15
- Filling the solvent bottle, 3-2
- Filter
 - Air inlet, B-2
 - Solvent line, 3-2

Fittings, 5-3
 Air and gas, B-2, B-4
Fixed time mode, 3-16
Flow, 2-21
Flush%
 Method parameter, 3-26
Flushing
 Extraction step, 2-17
 Increasing volume to improve extraction, 3-41
 Troubleshooting, 4-4
Frit, cell cap, 2-7
Functional description
 TTL input, E-1
Fuses, 5-15, A-1

G

Gas, 2-18
 see also Nitrogen
 Flow path, 2-11
 Source requirements, B-1
 Troubleshooting leaks, 4-24
Gas lines schematic, C-3
Gauges, 2-9, B-9
Guidelines
 For developing methods, 3-40

H

Heater voltage range switch, B-6
Help button, 2-6
Hood, 2-10

I

Icons used in manual, 1-4
IEC safety requirements, 1-4
In-line filter, 3-2
Inlet filter, B-2
Inserting a schedule line, 2-6
Inserts, vial tray, 2-9, B-18
Installation
 Checking pressure gauges, B-9
 Facility requirements, B-1

Priming the system, B-18
Rear panel connections, B-2
Solvent compartment connections, B-11
Substituting nitrogen for air, B-20
TTL/Relay connections, E-3
Waste vial, B-13
Inverted edge, E-2
Inverted pulse, E-2
Iso-octane, 3-28

K

Key sounds
 Turning on and off, B-20
Keypad, 2-5
Keys
 see Buttons

L

Labeling
 Cells, 3-9
 Vials, 3-11
Laboratory air requirements, B-1
LCD, 2-2, 2-3
Leaks
 Gas/air, 4-24
 Liquid, 4-22
Load Method or Schedule screen, 3-43, 3-45
Loading
 Cell tray, 3-10
 Methods, 3-43
 Schedules, 3-45
 Troubleshooting, 4-5
 Vial tray, 3-13
Local mode, 2-22
Logging errors, 4-1

M

Maintenance, 3-49
TTL mode, 3-20
Manual
 Conventions, 1-3

ASE 200 Operator's Manual

- Description, 1-3
- MeCl₂, 3-28
- Menu
 - Button, 2-6
- Menus, 2-4
- Messages
 - Error, 4-1
 - Safety, 1-4
- Methanol, 3-28
- Method control, 2-22
 - Definition of, 3-24
 - Running under, 3-42
- Method Editor screen, 3-25
- Method mode, 3-10
- Preheat, 3-26
- Method rinse, B-21
- Methods
 - Creating, 3-25
 - Default parameters, 3-25
 - Definition of, 3-24
 - Development guidelines, 3-40
 - Editing, 3-29
 - Examples, 3-30
 - Numbering the default method, 3-42
 - Selecting an unused number, 3-27, 4-2, 4-16, 4-17, 4-18
 - Selecting parameters, 3-26, 3-27
 - Specifying in schedules, 3-35
- Module Setup screen, 3-15, B-19
- Multiple extractions, 3-39

N

- Na₂SO₄, 3-5
- Needle mechanism, 2-2, 2-9, 2-11
 - Replacing the source needle, 5-14
 - Replacing the vent needle, 5-12
 - Troubleshooting, 4-6
- Nitrogen, 2-11, 2-18, A-1
 - Gauge, B-9
 - Source requirements, B-1
 - Substituting for compressed air, B-20
- Normal edge, E-2
- Normal pulse, E-2
- Numeric buttons, 2-6

O

- O-rings, 3-9, B-15
 - Replacement schedule, 3-49, 4-14
 - Replacing, 4-22
- Fixed time mode, 3-17, 3-19
- Operating configuration
 - TTL input, E-1
- Operating features, 2-1
- Operating modes, 2-22
- Options
 - ASE 200 accessories, 1-2
 - Setting operating options, B-19
- Oven, 2-2, 2-11
 - Automatic shut-off, 3-51
 - Checking the compression pressure, C-2
 - Heat up and cool down, 3-44, 3-46
 - Troubleshooting, 4-4
 - Voltage range switch, B-6
- Oven Wait message, 3-44, 3-46

P

- Part numbers, D-1
- Parts replacement, D-1
- PEEK seal, cell cap, 2-7
 - Replacement procedure, 5-2
 - Replacement schedule, 3-49
- Periodic maintenance, 3-49
- Physical dimensions, A-1
- Post-extraction procedures, 3-47
- Power cord, B-5
- Power requirements, A-1, B-1
- Power switch, 2-2
- Power-up, 2-4, B-16
- Power-Up screen, C-1
- Preparing sample, 3-3
- Preparing to run, 3-1
- Pressure, 2-13
 - Checking the system air pressure, 4-14, C-2
 - Controlling, 2-21
 - Oven compression, C-2
 - Sealing the cell, 2-14
 - Selecting the unit of measure, B-20
 - Set point during extraction, 2-16, 3-27
 - To the solvent bottle, 2-21

Pressure gauges, 2-9, B-9
Pressure relief valve, 2-9, 2-11, 2-21
 Replacing, 5-10
Prime valve, 2-11, 2-21
Priming the system, 2-5, 3-14, B-18
Printing, 3-48
 Connecting a printer, B-20
 Troubleshooting, 4-25
Process, 2-11
Processing extracts, 3-47
Pulse input signal mode, E-2
Pump, 2-11, 2-21
 Solenoids, 3-49
 Specifications, A-2
Pump check valves, 5-4
Purge
 Method parameter, 3-26
Purge valve, 2-11, 2-21
Purging, 2-18

R

Real-time clock, B-20
Rear panel, B-2
Refilling the solvent bottle, 3-14
Regulators, B-10
Regulators screen, C-2
Relief valve, 2-9, 2-11, 2-21
 Cleaning/replacing, 5-10
Remote mode, 2-22
Replacing
 Cell frit and seal, 5-2
 Needles, 5-12
 Pressure relief valve, 5-10
 Pump check valves, 5-4
 Static valve, 5-11
 Tubing and fittings, 5-3
Reports, 3-48
 Do not print, 4-25
Reservoir, 2-9
 Connections, B-11
 Filling, 3-2
Revision numbers, C-1
Revisions, Moduleware, BIOS, B-17
Rinse button, 2-5

Rinse cycle, 2-5, 2-7, 3-14
 Automatic, 3-15, B-21
 Specifying in schedules, 3-35
Rinse tubes, 2-7, 3-10, B-15
Rinse vials, 2-8
Routine maintenance, 3-49
RTD, troubleshooting, 4-12
Running, 3-1
 Aborting a run, 3-46
 Under method control, 3-42
 Under schedule control, 3-45

S

Safety icons, 1-4
Safety messages, 1-4
Sample cells, 2-7, 2-11
 see also Cells
Samples
 Difficulty in extracting, 3-41
 Identifying in schedules, 3-35
 Preparing, 3-3
Saving methods, 3-27
Saving schedules, 3-35
Schedule control, 2-22
 Definition of, 3-24
Schedule Editor
 Default parameters, 3-34
Schedules
 Creating, 3-34
 Definition of, 3-24
 Deleting and inserting lines, 2-6
 Examples, 3-36
 Running, 3-45
 Saving, 3-35
 Specifying parameters, 3-35
 Using for method development, 3-40
Schematic
 Air and gas lines, C-3
 Solvent flow, 3-49
 System Overview, 2-11
Screen backlighting
 Adjusting, B-20
Screen contrast
 Adjusting, 2-4

ASE 200 Operator's Manual

- Screens, 2-3
 - Alternate status, 2-13, 3-44
 - Communication, 3-48
 - Current Status, 2-12, B-21
 - Diagnostic Menu, C-1, C-3, C-5
 - Error Log, C-4
 - Load Method or Schedule, 3-43
 - Method Editor, 3-25
 - Module Setup, 3-15, B-19
 - Power-Up, C-1
 - Regulators, C-2
 - Schedule Editor, 3-34
- Scrolling the schedule screen, 3-34
- Seals
 - Cell cap replacement procedure, 5-2
 - Cell cap replacement schedule, 3-49
- Select buttons, 2-6
- Selecting options, 2-6
- Sensors
 - Cell size, 2-7
 - Vial absent, vial full, 2-9, 3-11
- Serial number, 3-7, 3-9
- Service procedures
 - Changing fuses, 5-15
 - Cleaning/replacing pump check valves, 5-4
 - Replacing needles, 5-12
 - Replacing the cell frit and seal, 5-2
 - Replacing the pressure relief valve, 5-10
 - Replacing the source needle, 5-14
 - Replacing the static valve, 5-11
 - Replacing tubing and fittings, 5-3
- Set point temperature, 3-44
- Ship Kit, B-2
- Shutdown, 3-51
- Signal modes for TTL input, E-2
- Site requirements, B-1
- Skipping cell numbers, 3-34
- Solenoids, 2-21, 3-49
- Solvent
 - Controlling flow, 2-21
 - Filling the bottle, 3-2
 - Flow schematic, 3-49
 - Preparing, 3-1
 - Rinsing after changing, 3-14
 - Specifying in a method, 3-27, 3-28
 - Usage, 3-6
- Solvent bottle, 2-9, 2-11
 - Connections, B-11
- Solvent compartment, 2-2, 2-9
 - Connections, B-11
- Solvent flow path, 2-11
 - Troubleshooting, 4-6, 4-23
- Sonicating, 5-3, 5-5
- Source needle, 5-14
- Specifications, A-1, A-3
 - Air and gas, A-1
 - Cell, vials, trays, A-2
 - Electrical, A-1
 - Environmental, A-1
 - Oven, A-2
 - Physical, A-1
 - Pump, A-2
 - Sensors, A-3
 - Valves, A-3
- Stainless steel
 - Cell cap frit, 2-7
- Start button, 2-5
- Starting
 - A method, 3-43
 - A schedule, 3-45
- Static method parameter, 3-26
- Static valve, 2-11, 2-15, 2-16, 2-21
 - Replacing, 5-11
- Status screen, 2-12
 - Setting the display time-out, B-21
- Step Time, 2-13
- Steps, 2-11
 - Filling the cell, 2-15
 - Flushing the cell, 2-17
 - Heating and static, 2-16
 - Loading the cell, 2-14
 - Purging, 2-18
 - Unloading the cell, 2-19, 2-20
- Stopping a method or schedule, 2-5, 3-46
- Symbols, 1-5
- System air gauge, B-9
- System air pressure, 4-14, C-2
- System status, 2-13

T

- Temperature, 2-13
 - Increasing to improve extraction, 3-40
 - Reaching the set point, 2-14, 3-44
- Terminator plugs, B-8
- THF, 3-28
- Time, B-21
- Time Function In screen, E-2
- Toluene, 3-28
- Transducer, 3-49
- Tray
 - Cell, 2-2, 2-7, 3-10
 - Engaging/disengaging, 2-5
 - Vial, 2-2, 2-8, 3-11
- Trays button, 2-5
- Troubleshooting
 - Cell tray, 4-8
 - Electrical, 4-21
 - Error messages, 4-1
 - Excessive cell pressure, 4-11
 - Flushing, 4-4
 - Gas/air leaks, 4-24
 - Loading, 4-5
 - Needle mechanism, 4-6
 - Oven, 4-4
 - Pressure Relief valve, 4-24
 - Reports do not print, 4-25
 - RTD, 4-12
 - Safety condition, 4-6
 - Solvent flow blocked, 4-6
 - System has stopped, 4-20
 - Vial tray, 4-7
- TTL mode, 3-19
- TTL/Relay control, E-1
 - Connectors, E-1
 - Input operation, E-1
 - Input signal modes, E-2
 - Installation, E-3
 - Output operation, E-1
- Tubing, 5-3
 - Air and gas, B-2
 - Vent, B-4

U

- Unloading
 - Cell from the oven, 2-19, 2-20

V

- Valves
 - Pressure relief, 2-9, 2-11, 2-21, 5-10
 - Prime, 2-11, 2-21
 - Pump check valves, 5-4
 - Purge, 2-11, 2-21
 - Specifications, A-3
 - Static, 2-11, 2-15, 2-16, 2-21, 5-11
 - Troubleshooting, 4-24
- Valves' status, 2-13
- Vent lines, 2-9, 2-11
- Vent needle
 - Replacing, 5-12
- Venting
 - Pressure, 2-20
- Vial caps, 2-8
- Vial tray, 2-2, 2-8
 - Inserts for 40 mL vials, 2-9, 3-13, B-18
 - Removing and installing, 3-11
 - Rinse slots, 3-13
 - Troubleshooting, 4-7
- Vials, 2-2, 2-8, 2-11
 - Labeling, 3-11
 - Loading on tray, 3-13
 - Sizes of, 3-11
 - Specifications, A-2
 - Where to place a label, 3-12
- Voltage range switch, B-6
- Volume of solvent pumped, 2-13

W

- Waste vial, 2-9, 2-11
 - Installation, B-13
- Water, 3-28

